

SERVICE MANUAL FOR KH-900 ELECTROKNIT.

brother[®]

CONTENTS

1. PRODUCT CHARACTERISTICS	1	8. CHECKING THE NEEDLE SELECTOR	14
2. PRODUCT SPECIFICATIONS	1	9. DISASSEMBLY, ASSEMBLY, AND ADJUSTMENT OF K CARRIAGE	16
3. QUICK TROUBLESHOOTING CHART	2	9.1 Disassembling the K Carriage	16
4. NOTES OF CAUTION FOR CHECKING AND REPAIR	5	9.2 Assembling the K Carriage	21
5. CIRCUITRY CONFIGURATION	6	9.3 Functional Check of the K Carriage	26
5.1 Main PC Board	6	9.4 How to Adjust the K Carriage	27
5.2 Left Position Sensor PC Board and Right Position Sensor PC Board	6	10. DISASSEMBLY, ASSEMBLY, AND ADJUSTMENT OF L CARRIAGE	28
5.3 Encoder PC Board	6	10.1 Disassembling the L Carriage	28
5.4 Power	7	10.2 Assembling the L Carriage	30
5.5 Solenoid PC Board	7	10.3 How to Adjust the L Carriage	34
5.6 Relationship between Needle Selector Plate, Solenoid, Needle Number, and Belt Phase Signals	7	11. DISASSEMBLY AND ASSEMBLY OF THE MAIN BODY	36
5.7 Cartridge (Option)	7	11.1 Disassembling the Main Body	36
6. TEST PROGRAMS	8	11.2 Assembling the Main Body	38
6.1 Check 1 (C-1)	8	11.3 How to Adjust the Needle Bed Comb	42
6.2 Check 2 (C-2)	10	12. ADJUSTMENT AND CHECK OF THE NEEDLE SELECTOR MECHANISM	43
6.3 Check 3 (C-3)	11	12.1 Adjusting the Card Reader Guide Plate	43
6.4 Check 4 (C-4)	11	12.2 Adjusting the Rotary Cam Position	43
6.5 Check 6 (C-6)	11	12.3 Checking the Needle Selector Mechanism	44
7. CHECKING THE A.C. ADAPTER	13		

1. PRODUCT CHARACTERISTICS

1. The application of electronics to a pattern knitting device, and automatic needle selection through the internalization of pattern data utilizing a microcomputer.
2. Patterns stored in memory may be altered in a variety of ways:
 - ① The orientation of the pattern may be changed.
 - ② The pattern may be expanded to two times vertically.
 - ③ KHC and KRC patterns may be knitted by merely switching the pattern variation key.
3. The memory capacity for the original pattern is 24 stitches x 998 rows and 24 stitches x 82 rows.
4. Original patterns may be knitted through key input.
5. Patterns stored in memory are not erased when the power is turned off.
6. Original pattern data may be stored or called up with stitch pattern cartridge III.
7. Thread lace may be knitted with K carriage.

2. PRODUCT SPECIFICATIONS

Pitch, number of needles	4.5 mm, 200 needles
Weight	12 kg
Size	L 1059 mm x W 216 mm x H 97 mm
Color	White
Needle bed material	Tempered steel can be installed
Knit leader	KL116 may be used
KR-KHC-KRC usage	KR850, 830, 838, KHC820, KRC830/900 T carriages may be used (KA-8300) L carriage may be used (KA-9000) Intarsia carriage may be used (KA-8200) Linker may be used (KA-8310)
Auto carriages	KG93 may be used
Pattern programming device	PPD-120 may be used
Pattern needle device	Automatic needle selection by internal microcomputer
Voltage-power requirements	AC adapter 7.5V1A

3. QUICK TROUBLESHOOTING CHART

Trouble		Origin	Remedy	Notes
K carriage	K carriage does not move easily	1. Carriage cam sliding. Part is out of oil	1. Oil the butt of the needle and the stitch cam	
		2. Needle bed sliding. Part is out of oil	2. Oil front and rear rails of body and carriage	
		3. The sinker plate and gate peg are in contact	3. Correct sinker plate front-rear adjustment	See P. 27
		4. The sinker plate is lifting the knitting needle	4. Correct vertical adjustment of sinker plate	See P. 27
		5. The gage is too tight	5. Loosen knitting gage	
		6. Poor horizontal adjustment of rotary cam. (Rotary cam is positioned too much to the left.)	6. Correct horizontal adjustment of rotary cam	See P. 43
Knitting	Floating stitches. Stitches get tucked.	1. Too much gap between sinker plate and gate peg	1. Correct front-rear adjustment of sinker plate	See P. 27
		2. Too much gap between sinker plate and needle	2. Correct vertical adjustment of sinker plate	See P. 27
		3. Needle latch not functioning properly	3. Change needle	
		4. The gage is too tight	4. Loosen knitting gage	
	Stitches irregular (uneven) Lateral stripe is produced occasionally	1. Uneven speed in carriage operation	1. Make carriage operation speed constant.	
		2. Poor yarn feed	2. Loosen spring tension of the yarn tension disk	
		1. Attachment of needle bed comb uneven left to right	1. Adjust the needle bed comb position even left to right	See P. 42
The carriage gets stuck while knitting	1. The needle bed is damaged	1. Repair needle bed		
	2. The butt of the needle is damaged	2. Replace needle		
When the change knob is set to <KC>, end needle selection is not possible	1. End needle selection cam problem (function is heavy, worn)	1. Replace end needle selection cam	See P. 20, P. 21	
L carriage	The L carriage gets stuck midway and will not move	1. The gage is too tight	1. Loosen knitting gage	
		2. The L carriage was operated with pulling it up.	2. Operate carriage correctly	
		3. The spring plate is damaged	3. Replace spring plate	See P. 33
	Comb teeth catch stitches	1. The gage is too loose	1. Tighten knitting gage	
		2. Yarn feeds poorly	2. Use wax on yarn tension wax stand	
		3. Speed of operation is too fast	3. Operate in proper speed	
		4. Gate peg bent	4. Adjust the gate peg	

	Trouble	Origin	Remedy	Notes
L carriage	Stitches are dropped	1. Poor latch needle operation	1. Replace the needle	
		2. Gate peg bent	2. Adjust gate peg	
		3. Needle transfer plate position improper	3. Correct right-left adjustment of needle transfer plate	See P. 34
		4. Main cam improperly positioned	4. Correct front-rear adjustment of Main cam	See P. 31
		5. Spring plate position improper	5. Correct horizontal adjustment of spring plate	See P. 34
		6. Sinker plate bent	6. Correct bend in sinker plate	See P. 35
	End needle is selected	1. End needle selection change cam for L. is not properly set	1. Set end needle selection change cam for L. properly	
		2. End needle selection cam is bad	2. Replace end needle selection cam	
Needle selection	Wrong needle is selected	1. Encoder sensor P.C. board problem	1. Check encoder sensor P.C.B. by CHECK 1 (C-1)	See P. 8
		2. Right/Left position sensor problem	2. Check Right/Left position sensor P.C.B. by CHECK 1 (C-1)	See P. 8
		3. Main P.C. board problem	3. Replace the Main P.C. board when all other possibilities have been checked and no problem discovered	See P. 14
		4. Needle selector mechanism problem	4. Check needle selection mechanism and needle selector solenoid	See P. 14
		5. Carriage problem	5. Check carriage	See P. 26
		6. Power problem	6. Exchange AC adapter	
		7. Operation problem	7. Operate correctly	
Needle selection	The same needle does not come out	1. The butt or shank of needle bent	1. Replace needle	
		2. Left-right measurement problem between rotary cam lever and rotary cam	2. Correct right-left adjustment of rotary cam (needle selection mechanism)	See P. 43
	Unnecessary needles come out at 8 cycles	1. There is grease between the needle selector plates.	1. Wipe grease off needle selector plate	
		2. The N.S.P. operation lever is squeezed between the operation lever presser and the rotary cam holder body N.S.P. operation lever does not move easily.	2. Replace needle selector unit	See P. 37, P. 38
Needle selection	Knitting needle not selected at 8 cycles	3. Needle bent or broken	3. Replace knitting needle	
		4. Hook of needle selector plate spring is making contact with other needle selector plates	4. Correct to hook the needle selector spring	
Needle selection	Knitting needle not selected at 8 cycles	1. The butt or shank of needle bent	1. Replace knitting needle	
		2. Holes in needle bed worn and enlarged	2. Replace needle bed	

	Trouble	Origin	Remedy	Notes
Needle selection	No needle selection in 16th cycle	1. The rotary cam lever remains at lower position.	1. Lubricate the card reader guide plate	
		2. The position of card reader guide plate is too much to the left.	2. Correct horizontal adjustment of card reader guide plate	See P. 43
		3. Rotary cam is out of adjustment horizontally. Needle selector plate travel is too short (Rotary cam is positioned too much to the right.)	3. Correct horizontal adjustment of rotary cam	See P. 43
		4. Needle selector solenoid remains power on.	4. Check needle selector solenoid	P. 14, P. 15
	Unnecessary needles come out at 16th cycles	1. The rotary cam lever remains at upper position	1. Lubricate the card reader guide plate	
		2. Rotary cam is out of adjustment horizontally. Needle selector plate travel is too large (Rotary cam is positioned too much to the left.)	2. Correct horizontal adjustment of card reader guide plate	See P. 43
		3. Needle selector solenoid remains power off.	3. Check needle selector solenoid	P. 14, P. 15
		4. No gap or too much gap between rotary cam lever and armature.	4. Bend the tip of the armature.	See P. 44
	Needle selection position is off by 8 stitches	1. The position sensor is out of adjustment	1. Correct voltage adjustment of position sensor and mounting position	See P. 8
		2. Connection between belt and carriage connecting plate at carriage forward travel opening (especially that of the L carriage) is bad	2. Replace the connecting plate. Replace the belt pulley brake (Friction plate spring)	See P. 20, P. 21
		3. Belt connecting hole is damaged	3. Replace the belt	See P. 41
		4. Carriage and belt sensor circuitry system is bad	4. Replace the encoder PC board or replace the main PC board	
5. Slit disc is damaged		5. Replace the slit disc		
6. K carriage and L carriage judgment circuits are bad		6. Replace the left position sensor PC board, the encoder PC board, the main PC board, in that order *Check and replace the K carriage and L carriage sensor magnets		

4. NOTES OF CAUTION FOR CHECKING AND REPAIR

In order to avoid secondary damage, please pay attention to the following points:

- (1) When assembling or disassembling the machine, always ensure that the AC adapter is unplugged from the socket.
- (2) Be sure not to pull the plug by the cord when disconnecting it from the socket.
- (3) Tighten nuts and screws down securely.
- (4) Be sure not to lose any nuts, screws, or washers, and ensure not to leave any of them in the machine during assembly. These can be the cause of shorts in the electrical circuitry.
- (5) Do not damage the cords or PC boards with the soldering iron.
- (6) The electrical parts used in the machine can be damaged by static electricity. Therefore, be sure to handle PC boards by the edges and to refrain from allowing your hands to come into direct contact with parts.
- (7) When transporting PC boards, it is best to wrap them in aluminum foil or in an anti-static electricity bag. When transporting the main PC board assembly, always ensure that the lithium battery has been removed. Never wrap the assembly with the lithium battery still attached. Polyethylene and styrene can cause static electricity and should not be used for wrapping.
- (8) After the completion of assembly or disassembly, check to ensure that all connectors are properly connected and that the equipment operates normally.
- (9) The main power should be the same as the rating of the machine.
- (10) Ensure that the positive and negative terminals of the lithium battery are not shorted.

5. CIRCUITRY CONFIGURATION

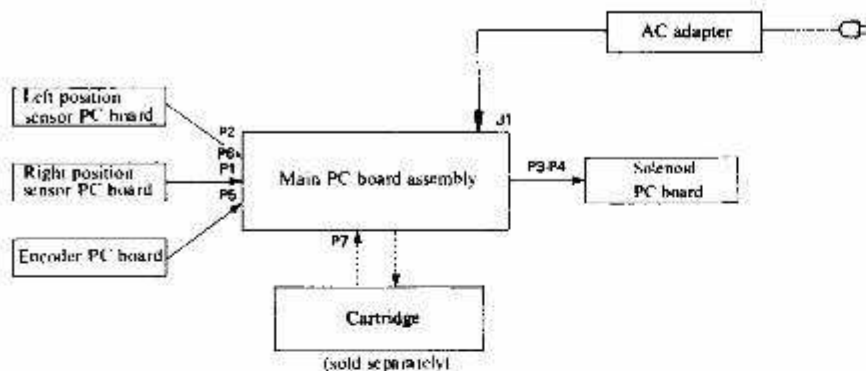

Figure 5-1

2) Fig. 5-1 shows the circuitry configuration of the KH-900.

5.1 Main PC Board

The main PC board is the main control portion of the equipment. It is comprised of the computer, memory, control parts, lamp (LED), and key, etc.

5.2 Left Position Sensor PC Board and Right Position Sensor PC Board

The left and right position sensor PC boards are what send out the carriage position signal. It is connected to the main PC board by a connector (S6, S1).

The position sensor signal (pin 3 of S6, S1) is normally DC 1.6-2.0V, but when the K carriage sensor magnet approaches the position sensor, it becomes DC 3.2V or more, and less than DC 0.9V when the L carriage approaches. When G carriage sensor magnet approaches, it begins at DC 0.9V and thereafter immediately changes to DC 3.2V or more. It is by these changes in voltage that the computer is able to judge which carriage has passed by (refer to Fig. 5-2).

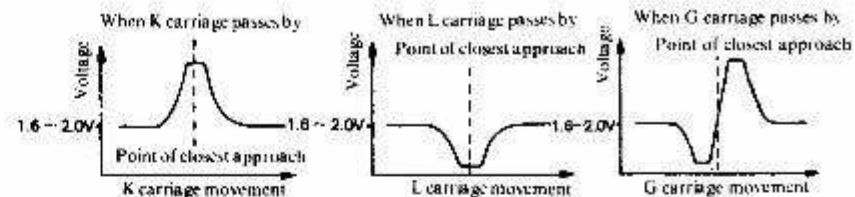

Figure 5-2

5.3 Encoder PC Board

The encoder PC board emits signals required in the detection of the direction and amount of carriage movement and in solenoid selection. It is connected to the main PC board by a connector (S5).

The V1 (Pin 4 of S5), V2 (Pin 3 of S5), and BP (Pin 5 of S5) signals are configured as shown in figure 5-3 below:

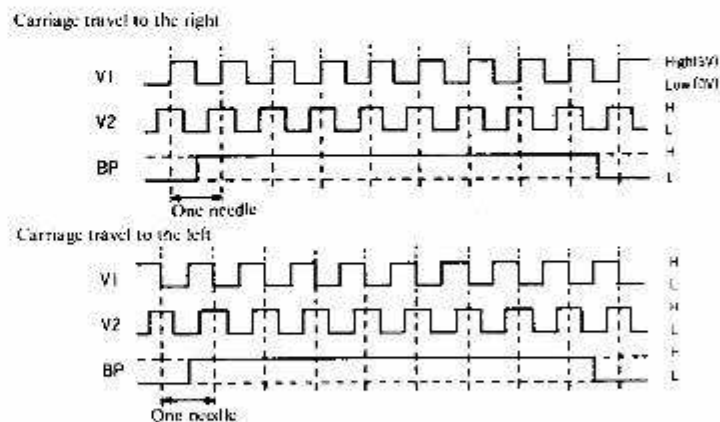

Figure 5-3

The amount and direction of movement of the carriage are detected via the V1 and V2 signals, and the type of engagement between the belt and the carriage is detected via the BP signal (Belt phase signal). There are two types of engagement, discriminated between by sensing whether the BP signal is high or low when the carriage passes the position sensor.

5.4 Power

The power uses exclusive adapter.

The generating power of the adapter is DC 7.5V and 1A ~ 1.2A.

The generating power of the adapter, which is changed into 5V by voltage regulator in the main PC board of the knitting machine, is supplied to computer and memory etc.

Polarity of the DC plug; outside (+)
inside (-) (see Fig. 5-4)

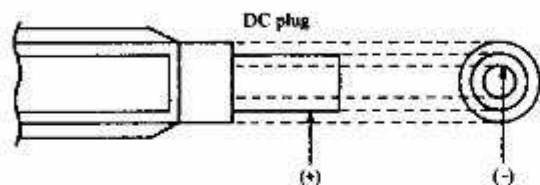

Figure 5-4

5.5 Solenoid PC Board

The solenoid PC board is a PC board which is acted upon by the needle selector device. It is connected to the main PC board assembly by a connector (S3, S4). There are 16 needle selector solenoids, with numbers on them, counted sequentially from left to right. There are 8 needle selector plates, the relationship to the rotary cam of which is given in figure 5-5 below.

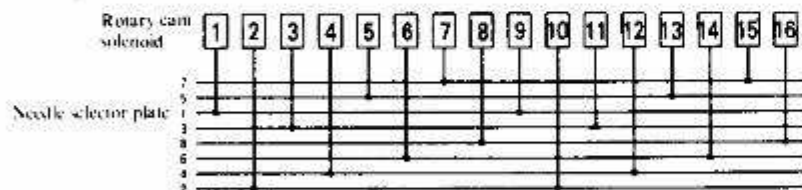

Figure 5-5

5.6 Relationship between Needle Selector Plate, Solenoid, Needle Number, and Belt Phase Signals

Needle selector plate	Solenoid	Yellow needle numbers (left)								Green needle numbers (right)					
1	1 9	100	84	68	52	36	20	4		13	29	45	61	77	93
2	2 10	99	83	67	51	35	19	3		14	30	46	62	78	94
3	3 11	98	82	66	50	34	18	2		15	31	47	63	79	95
4	4 12	97	81	65	49	33	17	1		16	32	48	64	80	96
5	5 13	96	80	64	48	32	16		1	17	33	49	65	81	97
6	6 14	95	79	63	47	31	15		2	18	34	50	66	82	98
7	7 15	94	78	62	46	30	14		3	19	35	51	67	83	99
8	8 16	93	77	61	45	29	13		4	20	36	52	68	84	100
1	9 1	92	76	60	44	28	12		5	21	37	53	69	85	
2	10 2	91	75	59	43	27	11		6	22	38	54	70	86	
3	11 3	90	74	58	42	26	10		7	23	39	55	71	87	
4	12 4	89	73	57	41	25	9		8	24	40	56	72	88	
5	13 5	88	72	56	40	24	8		9	25	41	57	73	89	
6	14 6	87	71	55	39	23	7		10	26	42	58	74	90	
7	15 7	86	70	54	38	22	6		11	27	43	59	75	91	
8	16 8	85	69	53	37	21	5		12	28	44	60	76	92	
BP signal	L	H	K carriage left turn mark												
	H	L	K carriage right turn mark												
	H	L	L carriage left turn mark												
	H	L	L carriage right turn mark												

5.7 Cartridge (option)

The cartridge is used to load the optional pattern and to save the patterns made by the PPD120 or KH-900. It is connected to the Main PC board connector (P7).

6. TEST PROGRAMS

Switch on the power as push the memo display key.
 Select the check No. with the up key or down key and push the memo display key after displaying "C-1".
 If you change the other check No., push the exec key in pause of the step.
 Select the check No. again after displaying "C-1".

6.1 CHECK 1 (C-1) Needle Position Detect Circuit Test

•Step 1 - Display right or left position signal output voltage.
 When the carriage pass the right or left position, it discriminate between the K, L, or G carriage.

(1) The voltage level of the right or left position signal will be indicated in the display. When there is no carriage in front of the sensor, a voltage level of 4 or 5 will be indicated.

In the event of the voltage level displayed in the display does not fall 4 or 5, adjust via the VR on the position sensor PC board assembly, as the voltage (between Pin 2 and Pin 3 of the connector S1 or S6) is $1.8V \pm 0.1V$.

Confirm the display that it displayed 4 or 5 after the adjustment.

When the voltage is not $1.8V \pm 0.1V$ even if you adjust the VR, change the position sensor PC board assembly.

When the display is not 4 or 5, change the main PC board assembly.

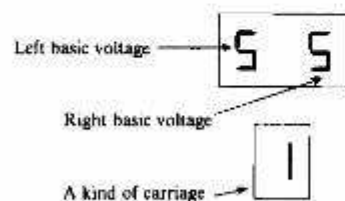

Figure 6-1

(2) When there is the magnet of the carriage in front of the sensor on the position sensor PC board assembly, there is the display as the chart 6-1.

When the magnet of the carriage pass across the outside of the sensor, it discriminate between the K, L, or G carriage, and indicate in the memo display.

K carriage 1 L carriage 2 G carriage 3

(3) When there is not voltage as the chart 1, or it can not discriminate the carriage, adjust the position sensor PC board assembly in front and rear or vertical as the fitting voltage. If there is not fitting voltage, change the position sensor PC board assembly.

If there is some abnormality during the G carriage check, check the G carriage sensor magnet. In the event that the magnet is properly mounted, replace the G magnet holder.

* The magnet with the white mark (N) is on the inside.

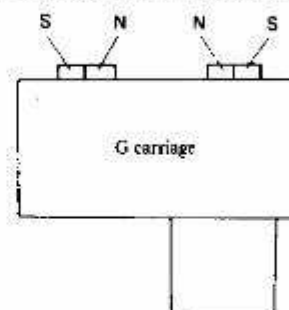

Figure 6-2

Basic voltage display	(Voltage (V) Power voltage 5.0V)	A kind of carriage
0	under 0.47	L
1	0.48 - 0.78	L (L judge level)
2	0.79 - 1.09	
3	1.10 - 1.40	
4	1.41 - 1.72	
5	1.73 - 2.03	
6	2.04 - 2.34	N (Change knob N)
7	2.35 - 2.66	N
8	2.67 - 2.97	N
9	2.98 - 3.28	(K judge level)
A	3.29 - 3.59	K
b	3.60 - 3.91	K
C	3.92 - 4.22	K
	4.23 - 4.53	K
E	4.54 - 4.84	K
No display	4.85 - 5.00	K

Chart 6-1

(4) Proceed to the step 2 at pushing the memo display key.

- **Step 2** — This is to check whether, of the needle position detect circuit signals, the V_1 , V_2 , and BP signals have been properly sent to the computer.

(5) Set the K carriage needle change knob to <KC>, and move the carriage forward and backward one time (20 needles or more).
If no problems are noted in step 2, a buzzer will sound, and the display will go off.

If a problem is noted during step 2, an "E" will be displayed in the memo display. When an "E" will be displayed in the memo display, the step will be proceed no further.

If the memo display key is pressed, the step 2 test will be repeated.

When there is a problem, the condition of the V_1 , V_2 , or BP signals will be indicated in a 3 digit display.

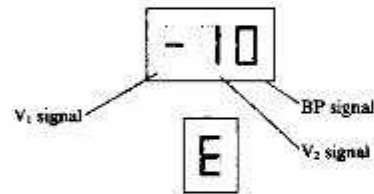

Figure 6-3

- : Proper condition
- 1 : The signal remains High
- 0 : The signal remains Low

(6) When there is a problem, replace the encorder PC board, then perform the check again starting with step 1.

(7) Proceed to the step 3 at pushing the memo display key.

- **Step 3** — Mounting position tests for the right and left position sensor PC boards.

(8) Move the carriage from the outside of the left turn mark toward the center. The step 3 test will begin.

(9) When the K carriage passes the left turn mark, and when the L carriage passes the right turn mark, during time from the belt phase signal reversing to the first V_1 count edge in the right or left position signal, the V_1 count edge should be one or more.

① K left turn mark

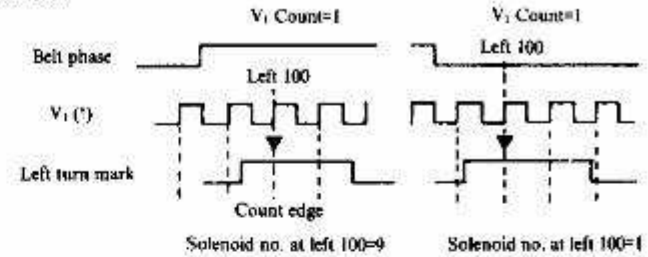

② L right turn mark

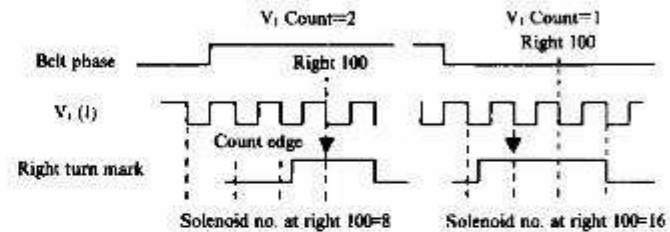

When the L carriage passes the left turn mark, and when the K carriage passes the right turn mark V_1 count edge should be one or more during the time from the first V_1 count edge in the right or left position signal to the belt phase signal reversing.

③ L left turn mark

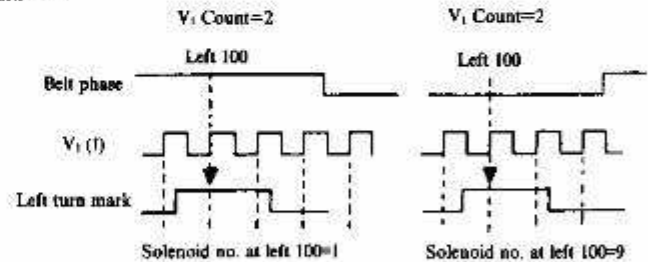

④ K right turn mark

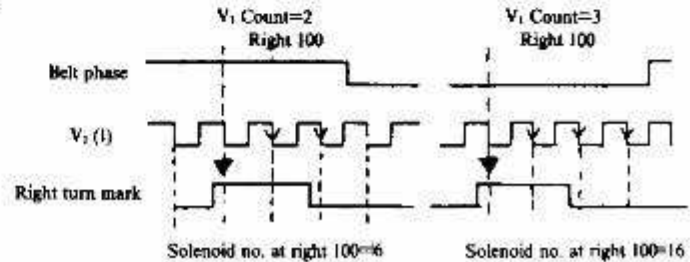

If there is no problem, the carriage type and belt phase signal level will be displayed in two digits. In the memo display, the digit for the count edge will be indicated.

First digit:	Belt phase signal	Display
	When H	1
	When L	0
Second digit:	Carriage type	Display
	K carriage	1
	L carriage	2
	G carriage	3

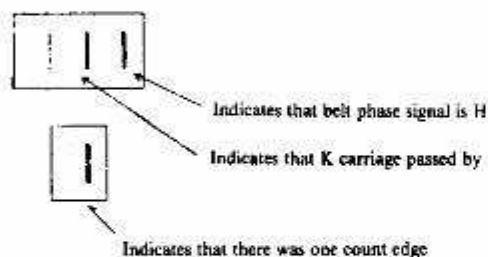

Figure 6-4

	Memo display carriage	Turn mark	Count edge
①	K	Left	1 ~ 2
②	L	Right	1 ~ 2
③	L	Left	2 ~ 3
④	K	Right	2 ~ 3

Chart 6-2

- (10) When there is a problem within step 3, an "E" will be displayed in the memo display, and also the carriage type and belt phase signal level will be displayed in the display.
- (11) When an error is registered, check the position sensor PC board via the items as given in chart 6-3. The standard position for the magnet sensor are at the 100th needle to the left and to the right. After checking these items, repeat the checks from step 1.

Error \ Item	Left position sensor	Right position sensor
When there is an error with the K carriage	Leans toward the inside	Leans toward the outside
When there is an error with the L carriage	Leans toward the outside	Leans toward the inside

Chart 6-3

- (12) Press the memo display key so that you can repeat the step 3 test. With the memo display key, when the belt phase signals ①, ②, ③, and ④ of step 3 are H or L, altogether, a total of 8 checks are performed.

6.2 CHECK 2 (C-2) Needle Number Indication

- (1) When the carriage sensor magnet passes the turn mark, the indication will start.
The position of the carriage sensor magnet (the magnet on the direction of travel for the G carriage) will be indicated by its needle number (the number of the needle position indicator).
It is normal for the actual sensor magnet position to differ from that indicated by one needle to the left or right. The computer will also be indicated, according to the needle then being indicated on the memo display. But the solenoid number B and D will be indicated each one of b and -, and the solenoid number F will be indicated no display.
And it will not be normal indicated at the outside of the 100th needle to the left and to the right.
- (2) When there is a problem, perform test program "C-1".

6.3 CHECK 3 (C-3) Memory Test

Check the inside RAM of the CPU, the S-RAM of the main body, and the RAM of the cartridge.

- (1) Insert the cartridge, then switch on the power as push the memo display key, and change the C-3 in the display by the up key and down key. If a buzzer will sound, and it will be indicated "C-1", there is no problem.

With the "C-3" in the display, when push the memo display key, check the inside RAM of the CPU, the S-RAM of the main body, and the RAM of the cartridge in that order.

- (2) When there is a problem, an "E" will be displayed in the memo display. When a "1" will be displayed in the memo display, there is a problem that the inside RAM of the CPU. When a "2" will be displayed, there is a problem that the S-RAM of the main body. When a "3" will be displayed, there is a problem that the RAM of the cartridge.
(If it is not inserted the cartridge, a "3" is displayed.)
- (3) If a "1" or "2" will be displayed, change the main PC board assembly. If a "3" will be displayed, change the cartridge and check it again.
When there will be error that change the cartridge yet, change the main PC board.

6.4 CHECK 4 (C-4) Display, Key, Buzzer Test

• Step 1 — Display check

- (1) With the "C-4" in the display, when push the memo display key, the display and lamp all light.
- (2) Proceed to the step 2 at pushing the memo display key.

• Step 2 — Key check

- (1) If a key is pushed, the number for that key should be displayed in the display and the buzzer sound.

The numbers for each of the keys is given in chart 6-4.

Display	Key	Display	Key
02	Memo display	0b	Double length
06	Up	0c	Reverse
05	Down	0-	Upside down
01	EXEC	0E	INPUT
04	FAST	0	C
07	PATTERN No.	10	STEP
08	POSITION	11	■
03	POINT	13	□
09	KRC	12	<△
0A	KHC	14	>

Chart 6-4

- (2) When the lamp is not lighted within step 1, or it is no display, the buzzer is not sound within step 2, change the main PC board assembly.

6.5 CHECK 6 (C-6) Checking the needle selector

There are checking patterns 1 through 4. The test is performed according to the following procedure.

- (1) With the "C-6" in the display, push the memo display key.
If the pattern No. key is pushed in succession, it will be indicated pattern No. 1 in the display. If you select the pattern No. that you want to check the pattern No. by up or down key, power lamp blinks and lights up, then selecting pattern is possible to select the needles.
- (2) Turn on the double length key of the variation keys, and set the K carriage change knob to <KC>.
- (3) Put a sufficient number of needles in position B, and select needles after passing the K carriage from the outside of the turn mark. The needle selection should change after every other pass.

•Test patterns



[1]: 1x1 alternative needle selection



[2]: 5x5 alternative needle selection

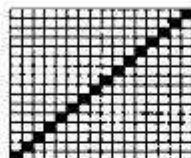

[3]: 1/16 needle selection



[4]: 1/5-5/5 needle selection

Figure 6-5

- (4) Check the patterns of 1 through 4 according to the pattern number key, the up and down key, and the pattern number key.

6.6 How to clear the RAM of the knitting machine

With the "C-1" in the display, when push the C key, it will be cleared the RAM of the knitting machine.

7. CHECKING THE A.C. ADAPTER

KH-900 uses exclusive A.C. adapter.

As the D.C. output of the exclusive A.C. adapter is 9.5V ~ 14V in no resistance, follow the test procedure below:

•Test Procedure

- (1) Turn off the power switch of the knitting machine. Pull out the A.C. adapter from the knitting machine and the outlet.
- (2) Check that the voltage of the outlet is within $\pm 10\%$ of the rated input voltage. (If it is less than -10% of the rated input voltage, the knitting machine cannot work. If it is more than $+10\%$ of the rated input voltage, the knitting machine and the A.C. adapter may run hot and this is dangerous.)
- (3) If the voltage of the outlet is appropriate, plug the A.C. adapter into the outlet and check that the D.C. output is 9.5V ~ 14V.

Take care not to mishandle the plus and minus terminals of the tester. (And not to shortcircuit them.)

* If the D.C. output is not 9.5 ~ 14V Replace the A.C. adapter with the new one.

8. CHECKING THE NEEDLE SELECTOR

8.1 Checking with the Power Switch Turned Off

- ① Set the K carriage change knob to <KC>, and put all of the needles in position B.
- ② Turn the power switch off, and move the K carriage to check all the needles should be selected to position D.

***Note:**

The above check should be performed with the carriage traveling right, left, and at high speed and at low speed.

***If there is a problem**

Then it will be in the needle selector mechanism of the main body or in the carriage needle selector mechanism.

8.2 Checking with the Power Switch Turned On

- ① Set the K carriage change knob to <KC>, and put all of the needles in position B.
- ② Turn the power switch on, and push the **INPUT** key. The **INPUT** key lamp should light.
- ③ Select needles after the K carriage has passed the turn mark from the outside. At this point, the needles should all be selected to position B.

***Note:**

The above check should be performed with the carriage traveling right, left, and at high speed and at low speed.

***If there is a problem**

If there are needles selected to position D, perform the check given 8.3.

8.3 Checking with the Solenoid On

- ① Remove the two operation panel screws. While holding up the left side of the panel and sliding the panel toward the left, remove it from the main body with connectors on.
(*Place the removed panel on the rear of the main body case.)
- ② Remove the two cord cover screws and the cord cover.
- ③ Set the K carriage needle change knob to <KC>, and put all the needles in position A.
- ④ Turn the power switch on, and push the **INPUT** key (as in 8.2 ②).
- ⑤ Move the K carriage past the turn mark from the outside, and then move it from right to left. The armatures should all remain in the down position.



Figure 8-1

The fourth armature from the right is out of position.

***If a problem is found in the 8.2 check**

If a problem is found during the 8.2 check but the 8.3 check produced none, it will indicate a problem in either the needle selector mechanism of the main body or in the carriage needle selector mechanism (refer to 12 on P. 43 and 9.3 on P. 26.).

***If a problem is found in the 8.3 check**

It will indicate a problem in the electrical circuitry. Check this with the test program given in chapter C-1 and C-3. If this does not produce the answer, perform the check in 8.4 (the example shown in the picture is a solenoid no. "13" problem).

8.4 Checking the Solenoid

- Turn the power switch off, and disconnect connector S3 and S4 (P3 and P4 on the main PC board).

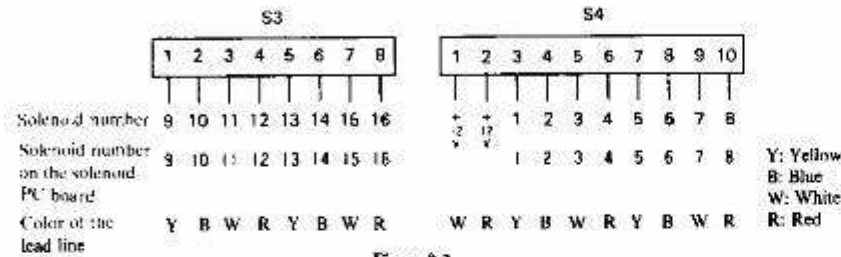

Figure 8-2

- Check the resistance between pin 1 or 2 of the S4 connector and the pin of the connector which corresponds to the unenergised armature. (Refer to figure 8-2. In picture 8-1, there is a problem in pin 1 of S4 or pin 2 and pin 5 of S3). Resistance should be within 100 - 123 Ω . If it is not, there is a problem, which may be found with the check given below. If no problem is found in the resistance values, perform the check given in test program C-1.
- Disconnect the needle selector solenoid unit (refer to on P. 37 item 10). Check the resistance values of the places which correspond to the solenoids on the solenoid PC board which were found to be bad. The resistance value of the solenoid coil should be between 100 - 123 Ω , the resistance value of the solenoid signal cord should be 0, and the resistance value of the metal portion of the main body and the solenoid should be $\infty\Omega$ (refer to figure 8-3).

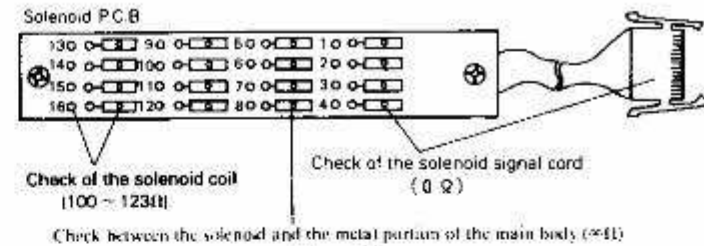
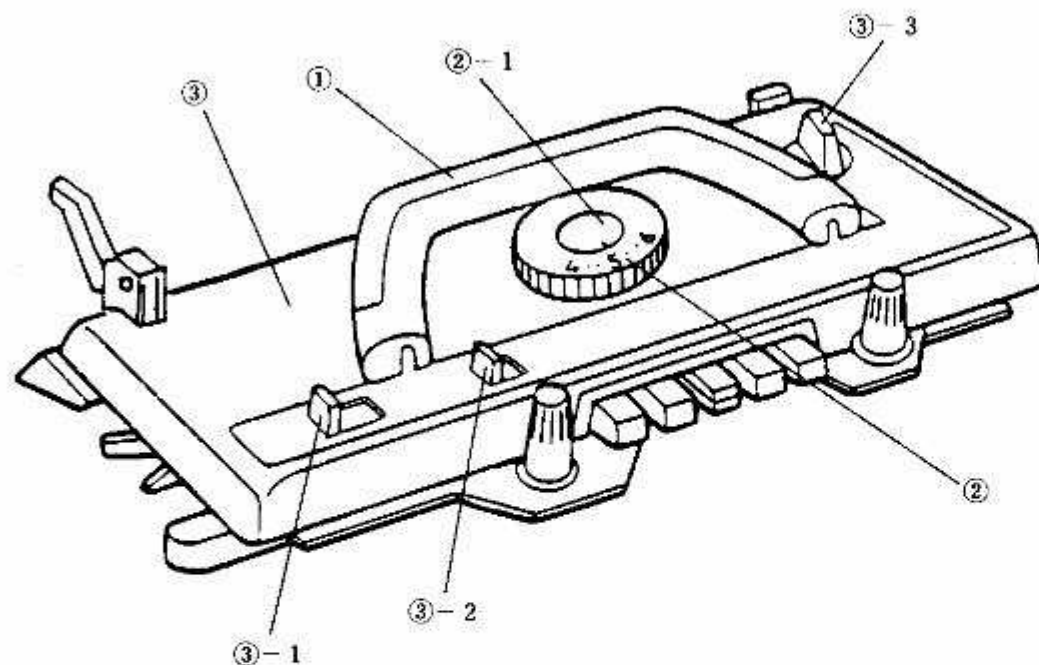

Figure 8-3

*If there is a problem

If a problem is found in a check between the solenoid coil and the solenoid chassis, replace the needle selector solenoid assembly. If a problem is found when checking the solenoid signal cord, replace the solenoid signal cord.

9. DISASSEMBLY, ASSEMBLY, AND ADJUSTMENT OF K CARRIAGE



Part Nomenclature

- ① Carriage handle
- ② Stitch dial
- ②-1 Stitch dial cap
- ③ Carriage cover
- ③-1 H.C.I. knob
- ③-2 Plain lever knob
- ③-3 Change knob

9.1 Disassembling the K carriage

1. Removing the carriage handle

- 1.1 Keep the handle down and remove the two right and left handle screws. Then the handle can be taken off the carriage.

2. Removing the stitch dial

- 2.1 Pull off the stitch dial cap upward.

- 2.2 Remove the fastening screw and pull off the stitch dial upward.

3. Removing the carriage cover

- 3.1 Loosen, from the back of the carriage, and remove the two right and left carriage cover clamp screws (tapping screws).
- 3.2 Pull off the carriage cover upward. Then the H.C.I. knob, the plain lever knob and the change knob will come off.

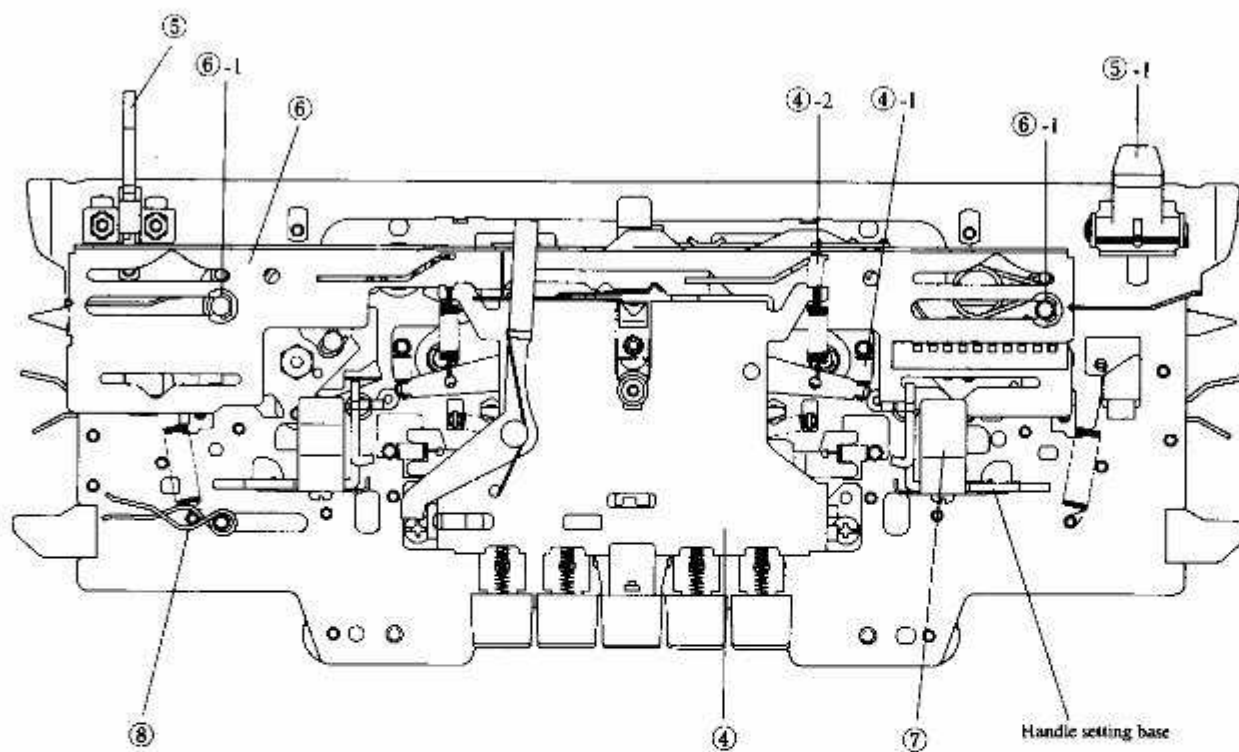

Part nomenclature

- ④ Cam button unit
- ④-1 Raising cam switch spring
- ④-2 Shift spring for K carriage sensor
- ⑤ Knit reader tripper
- ⑤-1 Row counter tripper
- ⑥ Upper slide plate
- ⑥-1 Snap ring
- ⑦ Handle lock spring
- ⑧ Front slide plate spring

4. Removing the cam button unit

- 4.1 Remove the raising cam switch spring from the cam button unit side.
- 4.2 Remove the shift spring for K carriage sensor from the K carriage sensor magnet.
- 4.3 Remove the two screws from the cam button unit, raise the cam button unit and separate the hammer in the screw section from the carriage plate, and pull it out toward you.

5. Removing the knit reader tripper and the row counter tripper

- 5.1 Remove the two screws from the knit reader tripper and the row counter tripper from the rear of the carriage.

6. Removing the upper slide plate

- 6.1 Remove the snap ring from the change knob shaft and the left side shaft.
- 6.2 Remove upper slide plate by lifting the left and right ends up at the same time.

7. Removing the handle lock spring

- 7.1 Remove the left and right handle lock spring screws from the handle setting base crimped onto the carriage plate.

8. Removing the H.C.L. spring

- 8.1 Remove the H.C.L. spring.

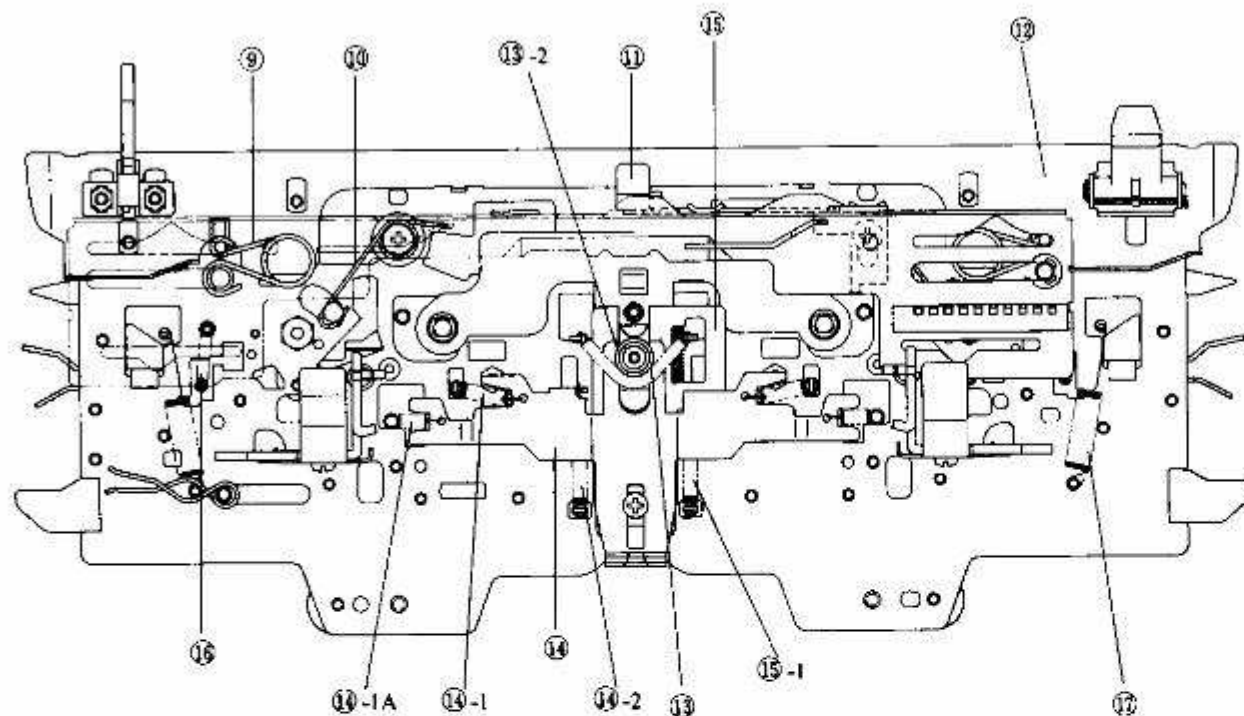

Part nomenclature

- ⑨ Connecting plate spring
- ⑩ Needle selection change spring
- ⑪ K carriage sensor magnet
- ⑫ Rear plate
- ⑬ Tuck cam spring
- ⑬-2 Tuck cam spring collar
- ⑭ Change plate A
- ⑭-1 MC cam spring
- ⑭-1A MC cam spring
- ⑭-2 Change plate A spring
- ⑮ Change plate B
- ⑮-1 Change plate B spring
- ⑯ End needle selection spring
- ⑰ Valve cam F spring

9. Removing the connecting plate spring

9.1 Lift and pull off left and right connecting plate springs.

10. Removing the needle selection change spring

10.1 Remove right and left needle selection change springs.

11. Removing the K carriage sensor magnet

11.1 Take out the two shafts for K carriage sensor magnet and remove the K carriage sensor magnet and the washer.

12. Removing the carriage rear plate

12.1 Raise the carriage rear plate as it is and remove it.

13. Removing the tuck cam spring and presser ring collar

13.1 Remove the hooks on the two ends of the tuck cam spring from the tuck cam spring hook catches.

13.2 Remove the tuck cam spring collar from the stitch dial shaft.

14. Removing change plate A

14.1 Remove the four left and right MC cam springs and the four left and

right MC cam springs A from the cam side.

14.2 Remove the change plate A spring (black) from the carriage front foot side.

14.3 Remove the change plate guide collar and lift change plate A up and out.

15. Removing change plate B

15.1 Remove change plate B spring from the carriage front foot side.

15.2 Remove change plate B spring and lift change plate B up and out (as well as the stitch cam collar).

16. Removing the end needle selection spring

16.1 Remove the end needle selection spring from the pin crimping to the carriage plate.

17. Removing valve cam F spring

17.1 Remove valve cam F spring from valve cam F and the front slide plate set screw.

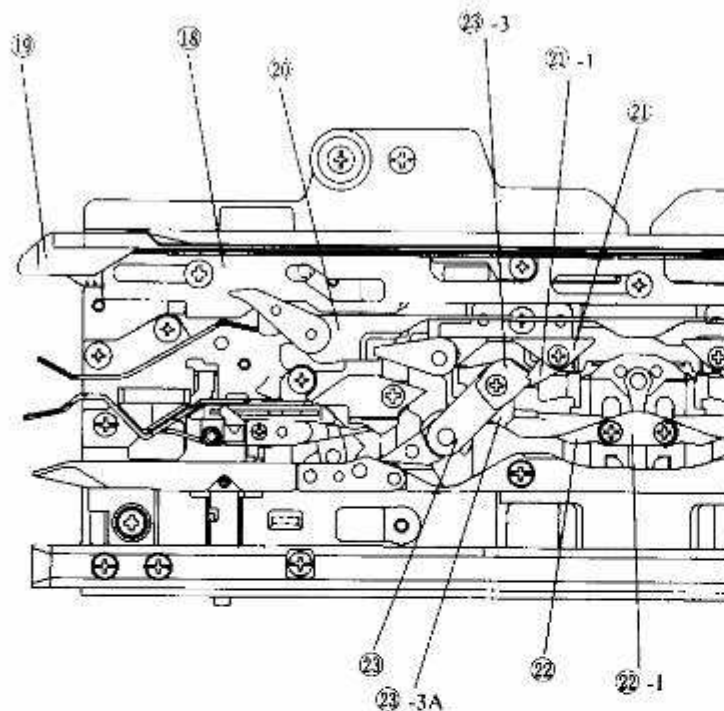

Carriage front side

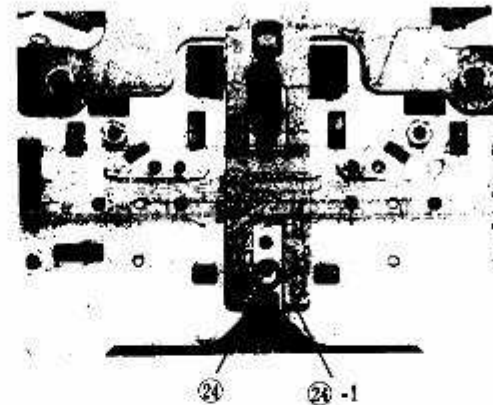

Part nomenclature

- 18 Front slide plate
- 19 Carriage front foot
- 20 Guide cam A
- 21 Guide cam B
- 22 -1 Valve cam B
- 22 Tuck cam
- 22 -1 Tuck cam plate
- 23 Stitch cam
- 23 -3 Sub stitch cam
- 23 -3A Valve cam D
- 24 Stitch cam collar
- 24 -1 Stitch cam guide plate

***Carriage rear**

18. Removing the front slide plate

18.1 Remove the two set screws on the left and right and the one in the center of the front slide plate, and lift the front slide plate up and off.

19. Removing the carriage front foot

19.1 Remove the two carriage front foot clamp screws and then the foot itself.

20. Removing guide cam A

20.1 Remove the two left and right guide cam A clamp screws and then the cam itself (slide cam as well).

21. Removing guide cam B and valve cam B

21.1 Remove the left guide cam B screw as well as the left valve cam B screw and remove the left guide cam B (as well as the left valve cam B, the left valve cam B spring, and valve cam B shaft). Remove the right guide cam B in a similar way (as well as the slide cam guide).

22. Removing the tuck cam

22.1 Remove the tuck cam plate screws and remove the tuck cam plate and the tuck cam (as well as the washer and the tuck cam shaft).

23. Removing the stitch cam

23.1 Remove the snap ring on the left and right stitch cam shaft from the front side of the carriage.

23.2 Remove the nut from the sub stitch cam from the front side of the carriage.

23.3 Remove the left stitch cam clamp screw, and the left sub stitch cam, the left stitch cam, the left valve cam D, the left valve cam D spring, the sub stitch cam shaft, and the left MC cam will all come off.

23.4 Remove the right stitch cam in a similar way.

24. Removing the stitch cam guide plate

24.1 When the snap ring E7 on the left and right of the stitch cam shaft and the left and right raising cam guides are removed, the stitch cam collar and the stitch cam guide plate will come off.

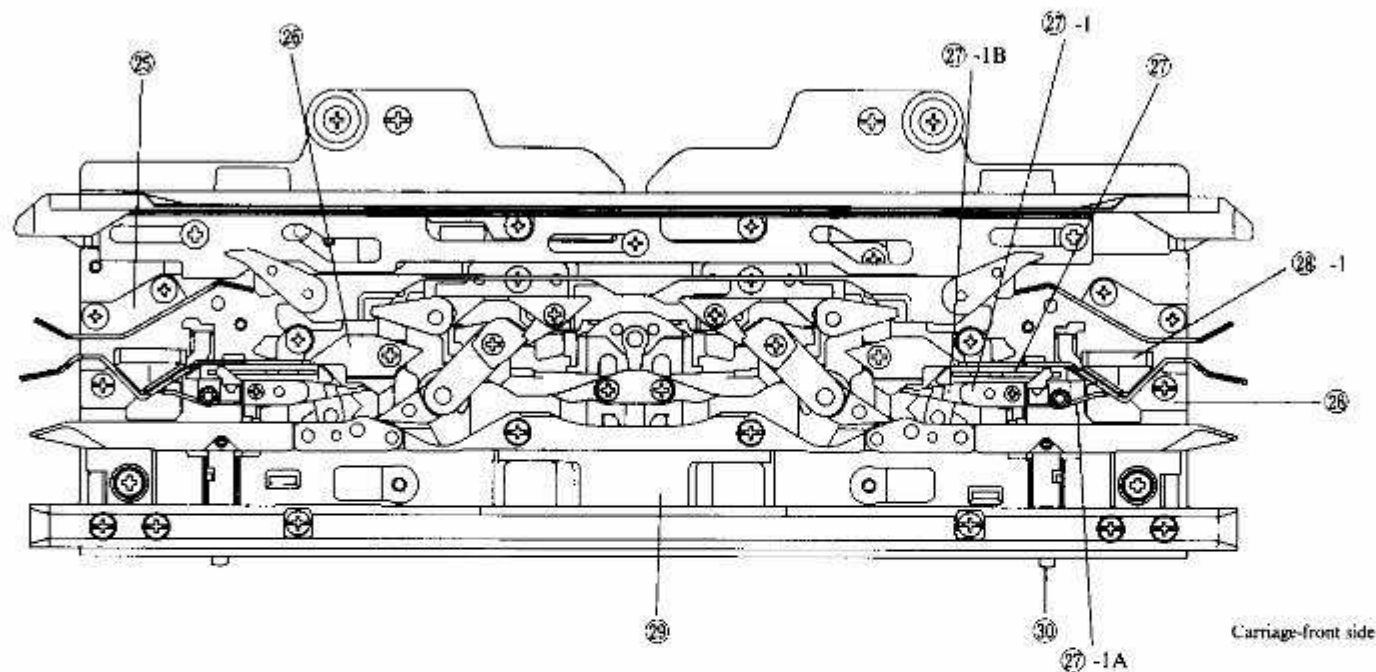

Part nomenclature

- 25 Guide cam F
- 26 Cam plate
- 27 Needle selection cam
- 27-1 Guide cam G
- 27-1A Valve cam F
- 27-1B Needle selection change cam
- 28 Separation cam
- 28-1 Buffer for selected needle
- 29 Carriage rear foot
- 30 Connecting plate

25. Removing guide cam F

25.1 Remove the left and right guide cam F clamp screws, and the left and right guide cam F will come off.

26. Removing the guide cam D

26.1 Remove the guide cam D screws and take the guide cam D off.

27. Removing the needle selection cam

27.1 Remove the guide cam G screws, and guide cam G, valve cam F, the needle selection change cam, and the needle selection cam will come off.

28. Removing the separation cam

28.1 Remove the separation cam screws, and the separation cam and the buffer for selected needle will come off.

29. Removing the carriage rear foot

29.1 Remove the six carriage rear foot screws, and the carriage rear foot will come off.

29.2 Remove the end needle selection cam, the end needle selection guide, end needle selection switch cam, end needle selection cam spring guide cam C, and the guide cam C spring.

30. Removing the connecting plate

30.1 Pull off the connecting plate by lifting it by its right and left parts near the front foot.

Part nomenclature

- ① Connecting plate
- ② Carriage rear foot
- ②-1 Guide cam C
- ②-1A End needle selection cam
- ②-1B End needle selection guide
- ③ Needle selection cam shaft
- ④-1 Buffer for selected needle
- ④-2 Separation cam
- ⑤ Needle selection cam
- ⑤-1 Valve cam F
- ⑤-1A Needle selection change cam
- ⑤-1B Guide cam G
- ⑥ Guide cam D

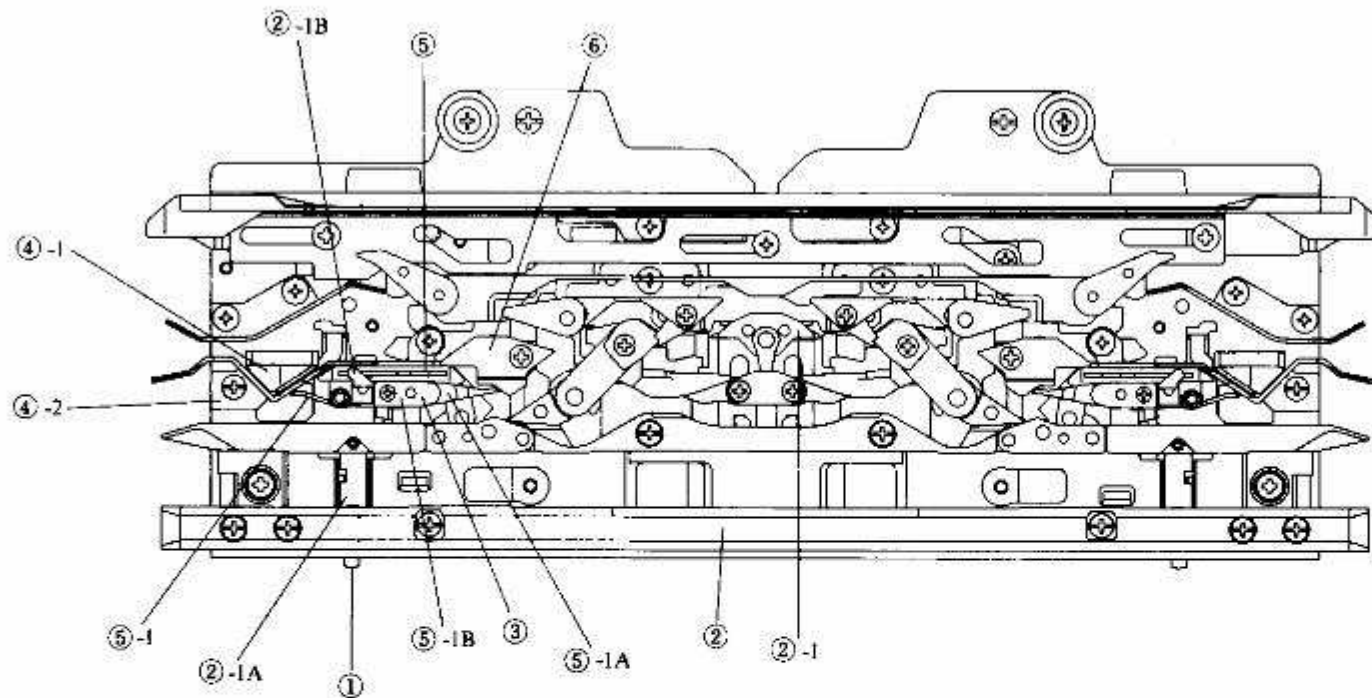

9.2 Assembling the K carriage

1. Mounting the connecting plate

1.1 Fit the left and right connecting plate into the carriage plate.

2. Mounting the carriage rear foot

2.1 Place the guide cam C spring on guide cam C and place guide cam C in the center of the carriage. After mounting the left and right end needle selection cam, the left and right needle selection guide, the end needle selection switch cam, end needle selection cam spring, mount the carriage rear foot and tighten the screws.

3. Mounting the needle selection cam shaft

3.1 Place the needle selection cam shaft in from the rear side of the carriage and

secure the needle selection cam shaft and tighten the nuts in from the front side of carriage.

4. Mounting the separation cam

4.1 Fit both buffers for selected needle into the square holes of the carriage plate.

4.2 Mount the left and right separation cam with the screws.

5. Mounting the needle selection cam

5.1 Mount the valve cam F and the needle selection change cam and check the positioning of the needle selection cam. When this has been mounted, tighten the screws onto both this and guide cam G.

6. Mounting the guide cam D

6.1 Check the guide cam D and assemble it to the shaft, then tighten screws.

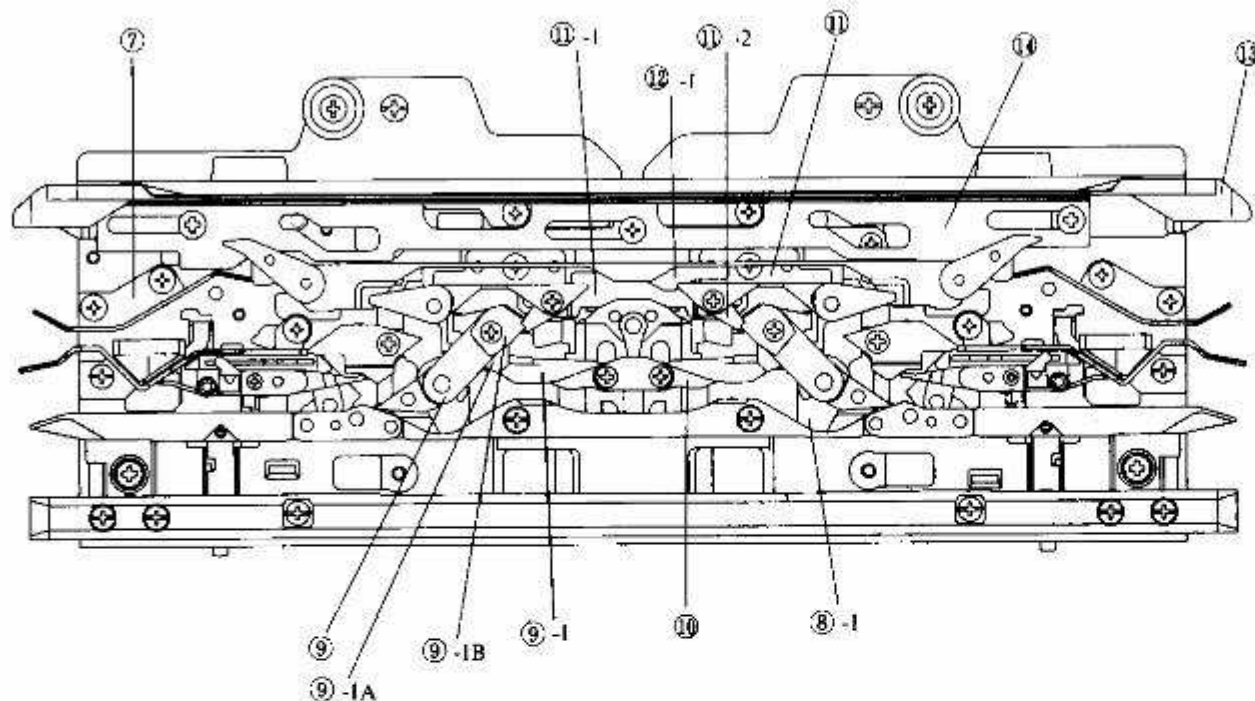

Part nomenclature

- ⑦ Guide cam F
- ⑧-1 Raising cam guide
- ⑨ Stitch cam
- ⑨-1 MC cam
- ⑨-1A Valve cam D
- ⑨-1B Sub stitch cam
- ⑩ Tuck cam
- ⑪ Guide cam B
- ⑪-1 Slide cam guide
- ⑪-2 Valve cam B
- ⑫ Guide cam A
- ⑫-1 Slide cam
- ⑬ Front carriage foot
- ⑭ Front slide plate

7. Mounting the guide cam F

7.1 Mount and tighten the two screws of guide cam F.

8. Mounting the stitch cam guide plate

8.1 Mount the stitch cam guide plate from the front side of the carriage. Pass the stitch cam guide plate shaft through the right and left raising cam guide from the rear side of the carriage. Fasten it down with snap ring E7. *Ensure that the tip of the raising cam guide enters the carriage plate and is secured.

9. Mounting the stitch cam

9.1 Fit the MC cam, the sub stitch cam shaft, the valve cam D spring, valve cam D, the stitch cam, and the sub stitch cam, in that order, to the carriage plate and tighten it all down with a screw. Ensure that valve cam D functions with its spring.

9.2 Mount the two snap rings E3 from the front side of the carriage.

9.3 Mount the two nuts from the front side of the carriage.

10. Mounting the tuck cam

10.1 Fit the tuck cam shaft, the left and right tuck cam, the tuck cam washer, and the tuck cam plate, in that order, to the top of guide cam C and

tighten it all down with a screw.

11. Mounting guide cam B and valve cam B

11.1 Insert the slide guide into the carriage plate.

11.2 Fit the valve cam B spring, the valve cam B shaft, valve cam B, and guide cam B, in that order, onto the top of the slide cam guide and tighten the valve cam B screw.

11.3 Tighten the screws on the right and left guide cam B. Valve cam B is on the inside of the sub stitch cam and should function with the spring.

12. Mounting guide cam A

12.1 Fit the slide cam to the slide cam guide.

12.2 Tighten the two screws on the right and left of guide cam A (such that the cam slides easily).

13. Mounting the front carriage foot

13.1 Tighten the front carriage foot on with the two screws.

14. Mounting the front slide plate

14.1 Put the front slide plate on top of the front carriage foot and tighten it on with 2 screws on the right and left and one screw in the middle.

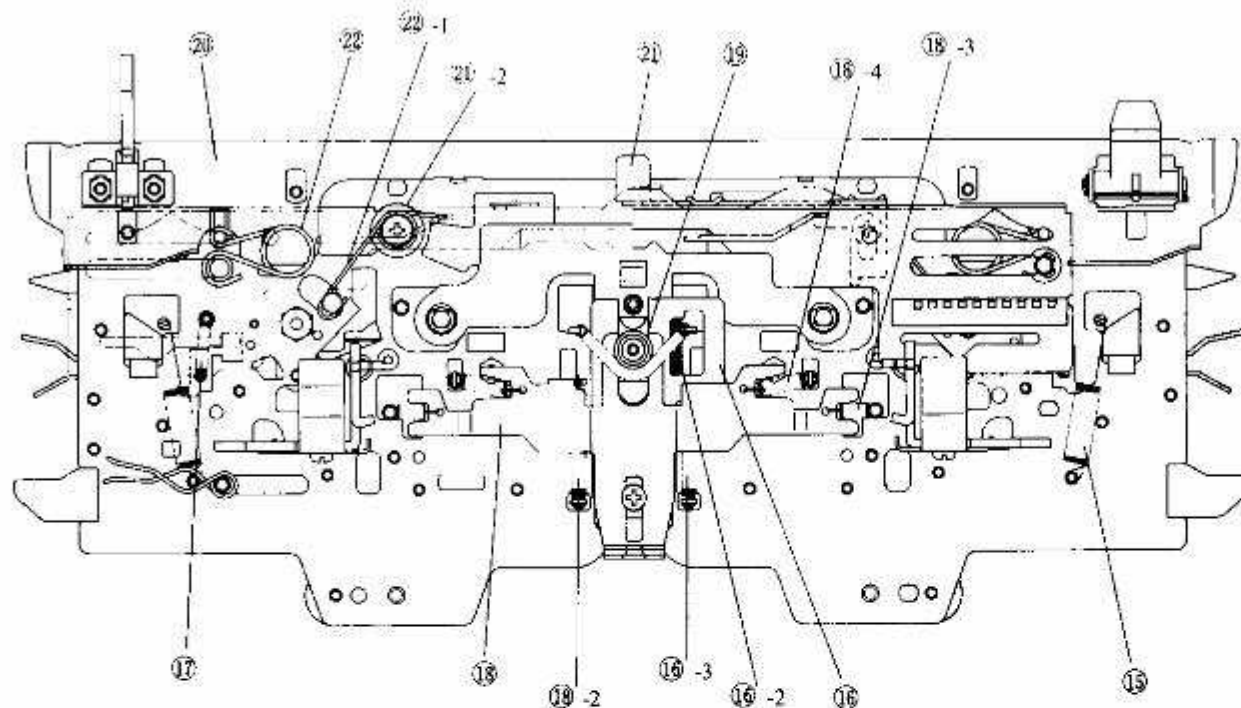

Part Nomenclature

- 15 Valve cam F spring
- 16 Change plate B
- 16-2 Change plate spring
- 16-3 Change plate B spring
- 17 End needle selection cam spring
- 18 Change plate A
- 18-2 Change plate A spring
- 18-3 MC cam spring
- 18-4 MC cam spring A
- 19 Tuck cam collar
- 19-1 Tuck cam spring
- 20 Carriage rear plate
- 21 K carriage sensor magnet
- 21-2 Washer
- 22 Connecting plate spring
- 22-1 Needle selection change spring

15. Mounting the valve cam F spring

15.1 Hook the valve cam F spring to the screw protruding from the carriage front foot and valve cam F.

16. Mounting change plate B

16.1 Put the stitch cam plate collar on the stitch cam plate groove.

16.2 While inserting the change plate spring, mount the dial shaft to change plate B.

16.3 Hook the change plate B spring to the carriage front foot.

17. Mounting the end needle selection cam spring

17.1 Hook the end needle selection cam spring over the end needle selection cam.

18. Mounting change plate A

18.1 Fit change plate A to the dial shaft and tighten the change plate guide collar in such a way that it passes through the stitch cam plate collar.

18.2 Hook the change plate A spring to the carriage front foot.

18.3 Hook the left and right MC cam spring and the left and right MC cam spring A onto their respective pins.

19. Mounting the tuck cam spring

19.1 Mount the tuck cam spring collar from the top of the dial shaft.

19.2 Hook the tuck cam spring onto the tuck cam. Hook it on in such a way that at the side with the change plate B spring, the opening part of hook of the tuck cam spring should be downside.

20. Mounting the carriage rear plate

20.1 Set the carriage rear plate.

21. Mounting the carriage sensor magnet

21.1 Mount the K carriage sensor magnet with the K carriage sensor magnet shaft.

21.2 Mount the washer with the K carriage sensor magnet shaft.

22. Mounting the connecting plate spring and needle selection change spring

22.1 Hook the connecting plate spring to the connecting plate calking pin and the change knob shaft.

22.2 Place the U shaped needle selection change spring over the needle selection change cam calking pin and over the K carriage sensor magnet shaft.

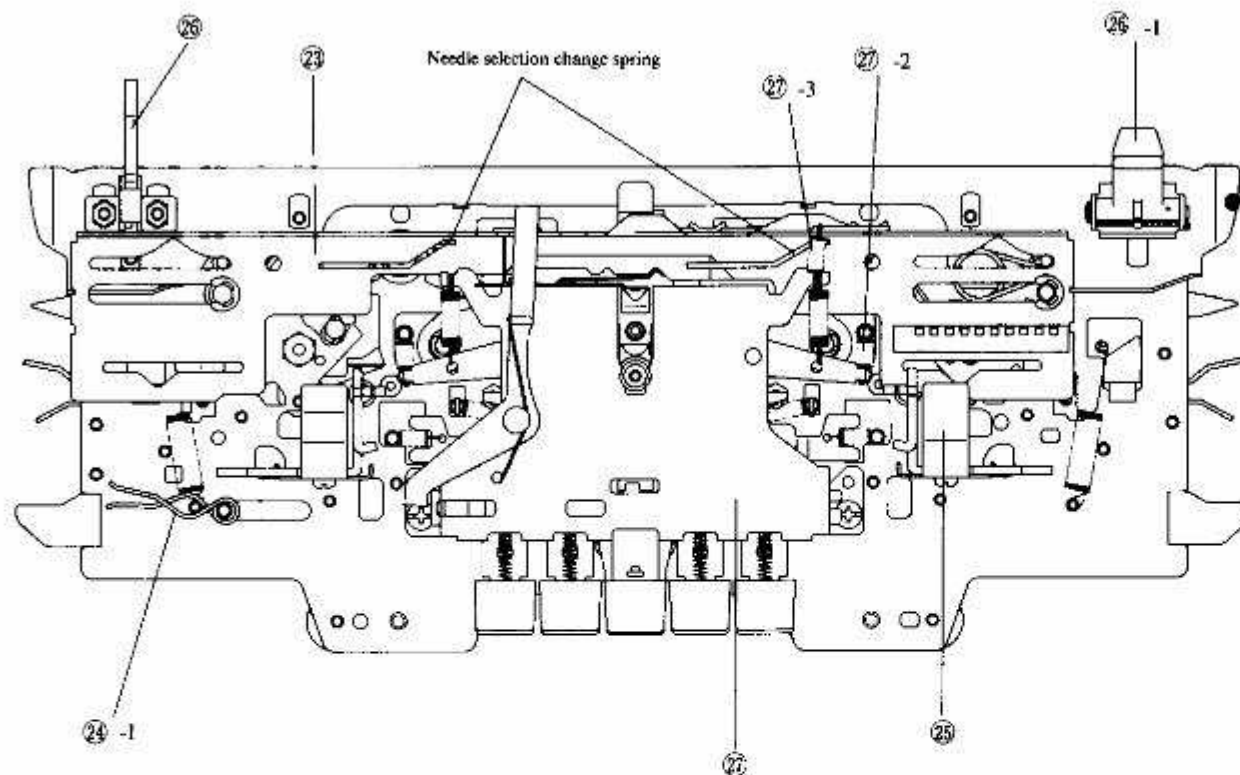

Part nomenclature

- 23 Upper slide plate
- 24 H.C.L. spring
- 25 Handle screw
- 26 Knit reader tripper
- 26-1 Row counter tripper
- 27 Cam button unit
- 27-2 Raising cam switch spring
- 27-3 K carriage sensor shift spring

23. Mounting the upper slide plate

- 23.1 Mount the upper slide plate and then insert the carriage plate calking pin, the change knob shaft, the left and right connecting plate calking pins, and left and right needle selection change spring into the long hole on the upper slide plate.
- 23.2 Fix the upper slide plate onto the carriage plate calking pin and the change knob shaft with a snap ring.

24. Mounting the H.C.L. spring

- 24.1 Insert the H.C.L. spring into the shaft of the upper slide plate and the screw.

25. Mounting the handle screws

- 25.1 Tighten the handle spring screws onto the handle setting base.

26. Mounting the knit reader tripper and row counter tripper

- 26.1 Place the knit reader tripper on the left and the row counter tripper on the right and tighten each of them from the rear side of the carriage with two screws.

27. Mounting the cam button unit

- 27.1 Mount the cam button unit to the stitch dial shaft and tighten the left and right sides with screws.
- 27.2 Hook the raising cam change spring to the raising cam calking pin.
- 27.3 Mount the K carriage sensor shift spring to the K carriage sensor magnet.

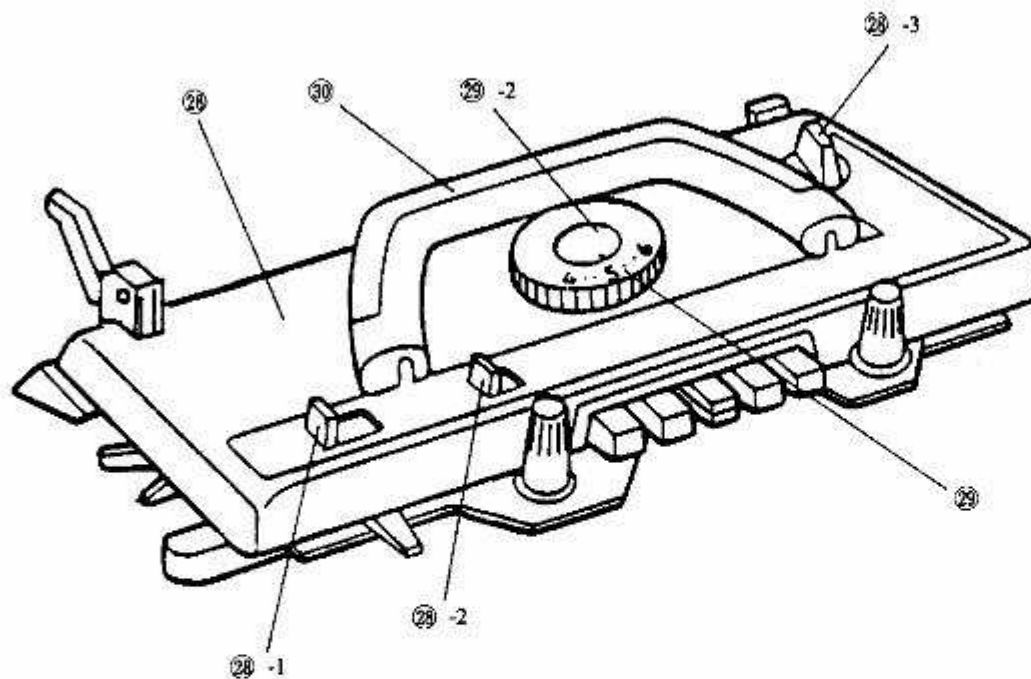

Part nomenclature

- 28 Carriage cover
- 28-1 H.C.L. knob
- 28-2 Plain lever knob
- 28-3 Change knob
- 29 Stitch dial
- 29-2 Stitch dial cap
- 30 Carriage handle

28. Mounting the carriage cover

- 28.1 Place the H.C.L. knob over the H.C.L. knob shaft.
- 28.2 Place the plain lever knob over the cam button unit.
- 28.3 Place the change knob over the change knob shaft (pay attention to the position).
- 28.4 Mount the carriage cover and tighten it down with screws (tapping screws) from the rear of the carriage.

29. Mounting the stitch dial

- 29.1 Fit the stitch dial on the shaft and tighten the screws in such a way that the notch in the stitch dial presser cap comes in front.
- 29.2 Bring the mark of the stitch dial presser cap to the notch in the knob retainer and put the cap in position. Align the line mark such that it is directly over the digits on the dial.

30. Mounting the carriage handle

- 30.1 Placing the handle in the down position, tighten it down on the left and right with screws.

9.3 Functional Check of the K Carriage

1. Functioning of the change knob

- 1.1 Switch the change knob from <N> to <KC> to <CR>, ensuring that each operates smoothly and that the left and right connecting plates, sensor magnets, left and right needle selection change cams, and the carriage rear plate make the switch properly.

2. Functioning of the MC cam

- 2.1 Without pushing the cam button, push the tips of the left and right MC cam up as far as they will go, and then help them down slowly with your fingers, ensuring that the left and right MC cam are returned properly to their original positions by the pressure of the spring.
- 2.2 Without pushing the cam button, check to ensure that the left and right tips of the MC cam are in proper contact with the tuck cam plate.

3. Functioning of the raising cam

- 3.1 Push the tips of the left and right raising cam as far as they will go setting the knitting dial scale (0 - 5 - 10) and, helping them down slowly with your fingers, ensure that the left and right raising cams are returned properly to their original positions by the pressure of the spring.

4. Functioning of the needle selection change cam

- 4.1 With change knob in the <KC> position, push the tips of the left and right needle selection change cam up as far as they will go, and, helping them down slowly with your fingers, they ensure that the left and right needle selection change cams are returned properly to its original positions by the pressure of the spring.

5. Functioning of the tuck cam

- 5.1 With the left and right tuck cam buttons pushed, push the left and right tips of the tuck cam up as far as they will go, and, helping them down slowly with your fingers, ensure that the left and right tuck cam are returned properly to their original positions by the pressure of the spring.
- 5.2 Put the cam button in the <N> position, and, with the tips of the left and right tuck cam pushed all the way down, ensure that the left and right tuck cam are returned properly to their original positions by the pressure of the spring.

6. Functioning of each of the valve cams

- 6.1 Rotate the tip of each of the valve cams with your fingers. Ensure that when you return them slowly with your fingers, the tip of each of the valve cams is properly returned by the pressure of the spring to its original position.

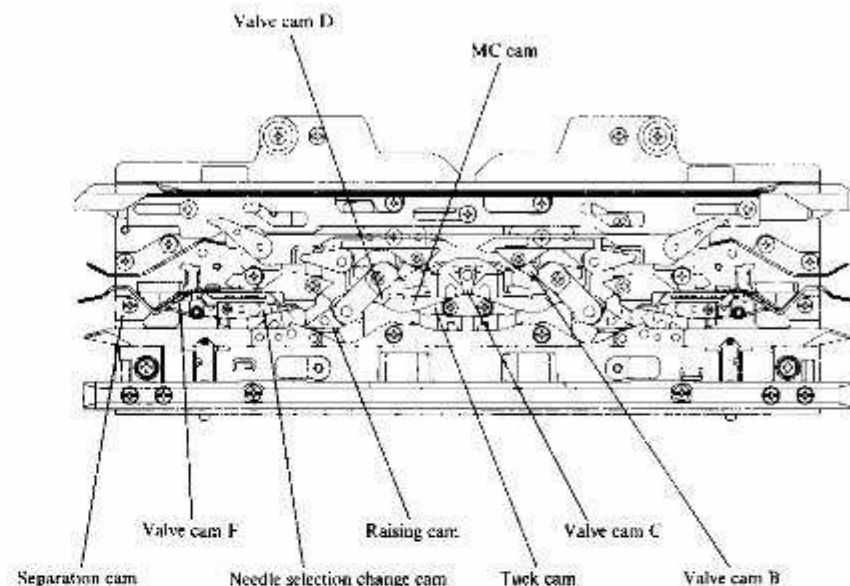

Figure 9-1

7. Functioning of the cam button unit

- 7.1 Switch the cam button from <TUCK> left and right, <MC>, <L>, and <PART> left and right, ensuring that the cam button unit operates smoothly and that left and right tuck cams, left and right MC cams, left and right MC change cams, guide cam C, and left and right raising cams switch properly.
- 7.2 With any one of the cam buttons pushed down, switch the change knob over from <KC> to <N>, ensuring that the cam button returns automatically.
- 7.3 With the sinker plate installed to the carriage, press the <L> button, ensuring that the yarn presser brush on the sinker plate switches properly.

8. Functioning of the H.C.L. knob

- 8.1 Switch the H.C.L. knob to <N> and <H>, ensuring that operation is smooth and that left and right change cams properly make the switch.
- 8.2 Ensure that the H.C.L. knob, when switched from <N> to <H>, stops at the <H> position properly.

9. Functioning of the plain lever knob

- 9.1 Push the <TUCK> left and right, <MC>, <L>, and <PART> left and right cam buttons, ensuring that when the plain lever knob is switched, operation is smooth and that the cam button returns properly to its original position.

9.4 How to Adjust the K Carriage

1. Front and rear adjustment of the sinker plate

- 1.1 Mounting dimensions of the sinker plate The proper distance of the sinker plate from the rear carriage foot is 118.3 mm. If this distance is out of specification, adjust it by loosening the six screws to the left or right of the sinker plate.
- 1.2 Mounting dimensions of the yarn feeder The yarn feeder should be 120.5 mm from the rear carriage foot.

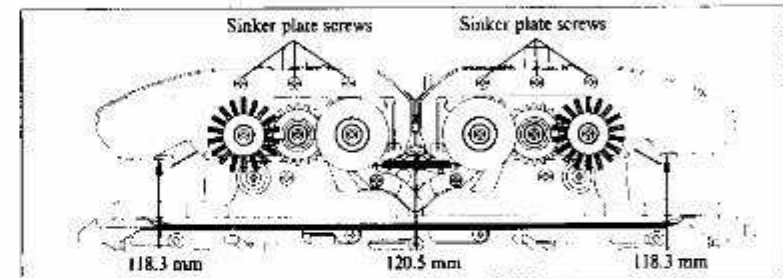

Figure 9-2

2. Vertical adjustment of the sinker plate

- 2.1 Place the carriage over the needle bed and put the H.C.L. knob on <H>.
- 2.2 Extend about five knitting needles to position E from three different places on the left, center, and right of the needle bed.
- 2.3 Bend the sinker plate to adjust it to make the gap between it and the knitting needle stem to within 0.5 mm.

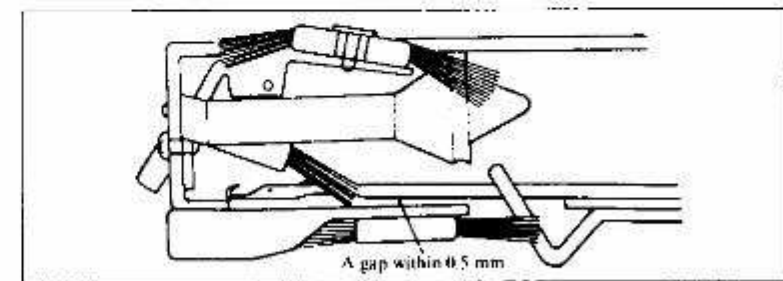
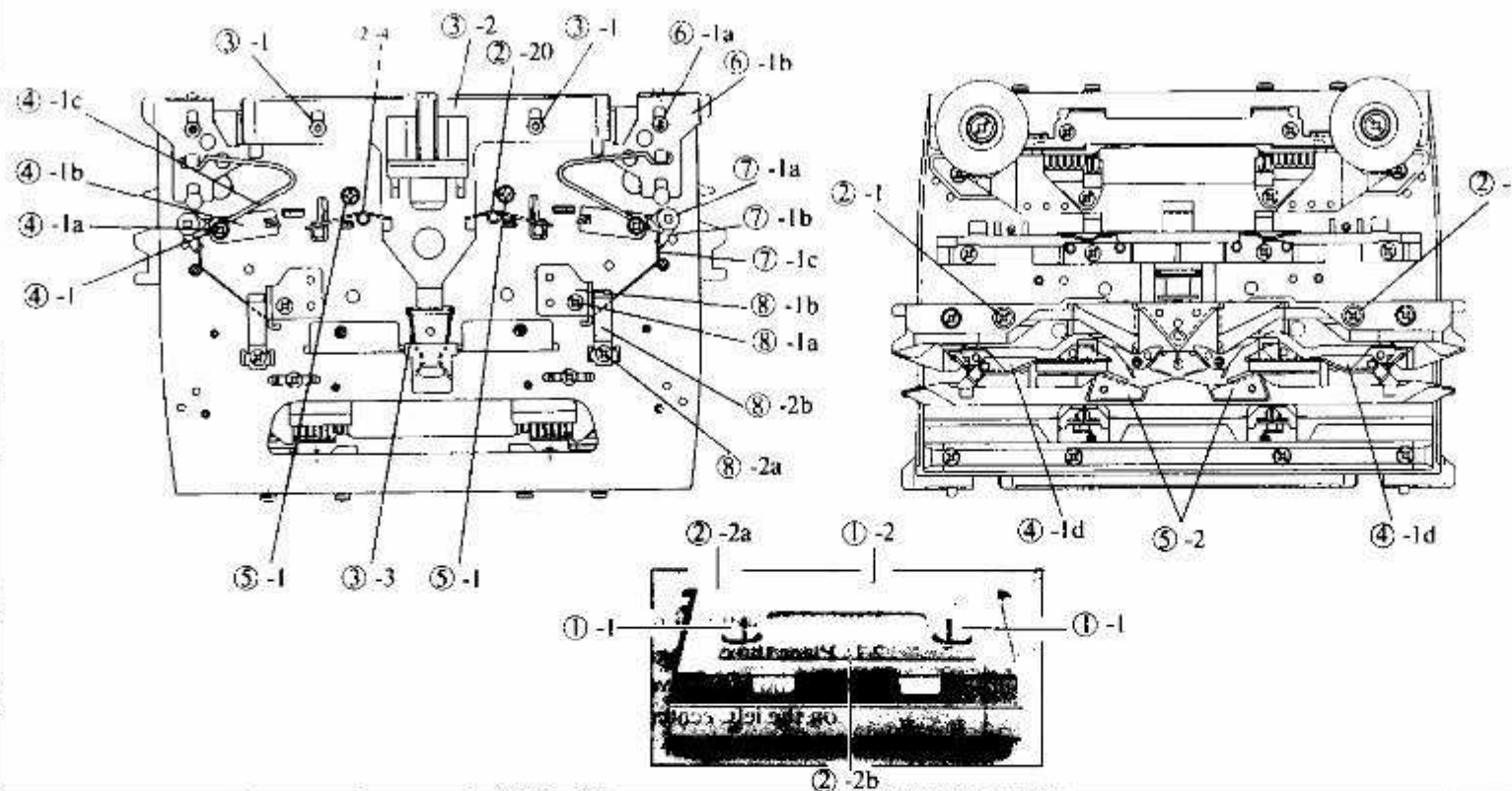

Figure 9-3

10. DISASSEMBLY, ASSEMBLY, AND ADJUSTMENT OF THE L CARRIAGE (OPTION)



Name of parts

- ①-1a Screw
- ①-1b L carriage handle
- ②-1 Screw 3.18 --- 40 × 4
- ②-2a L carriage cover
- ②-2b Lace selecting knob
- ②-2c Valve cam C spring
- ③-1 Stud nut
- ③-2 Release button plate
- ③-3 Change lever spring
- ④-1 L separation cam plate screw
- ④-1a Washer 3.3
- ④-1b Separation cam plate
- ④-1c Connecting plate spring
- ④-1d Separation cam
- ⑤-1 +- Screw 3.18 × 12
- ⑤-2 End needle separation cam
- ⑥-1a Stud nut
- ⑥-1b Connecting plate
- ⑦-1a Lever shaft (Stud screw)
- ⑦-1b Valve cam C
- ⑦-1c Valve cam C spring
- ⑧-1a Screw 3.57 --- 40 × 5
- ⑧-1b L handle setting base
- ⑧-2a Screw 3.57 --- 40 × 4
- ⑧-2b L handle spring

10.1 Disassembling the L carriage

1. Removing the L carriage handle

- 1.1 Keep the handle down and remove the right and left screws. Then the handle can be taken off the carriage.

2. Removing the L carriage cover

- 2.1 Removing the two L carriage cover screw.
- 2.2 Pull off the carriage cover upward. Then the lace selecting knob and the valve cam C spring will come off.

3. Removing the Release button plate

- 3.1 Remove the right and left stud nuts for release button plate.
- 3.2 Lift the release button plate and pull it out toward you.
- 3.3 Remove the change lever spring.

4. Removing the separation cam

- 4.1 Remove the separation cam plate screws from the front of L carriage, and the connecting plate spring, the separation cam plate, screws, washer, and the separation cam will all come off.

4.2 Remove the right and left in the same manner.

5. Removing the end needle separation cam

- 5.1 Removing the end needle separation cam screws (+- screw 3.18 × 12) the front side of the L carriage.
- 5.2 Remove the left and right end needle separation cams.

6. Removing the connecting plate

- 6.1 Remove the left and right stud nuts for connecting plate and detach the left and right connecting plates.

7. Removing valve cam C

- 7.1 Take off the lever shaft (stud screw) and remove the valve cam C and the valve cam C spring.

8. Removing the L handle setting base and the L handle spring

- 8.1 Remove the right and left L handle setting base screws and remove the L handle setting bases.
- 8.2 Remove the right and left handle spring screws and remove L handle springs.

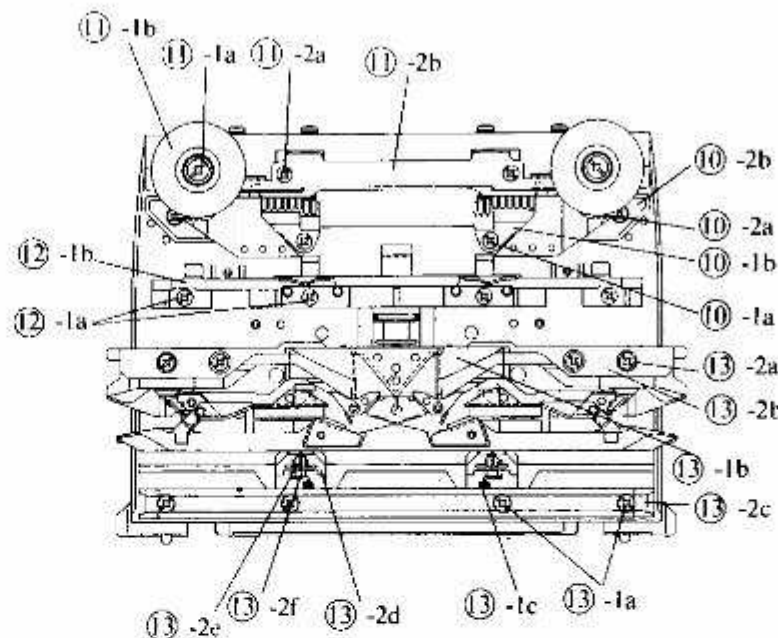
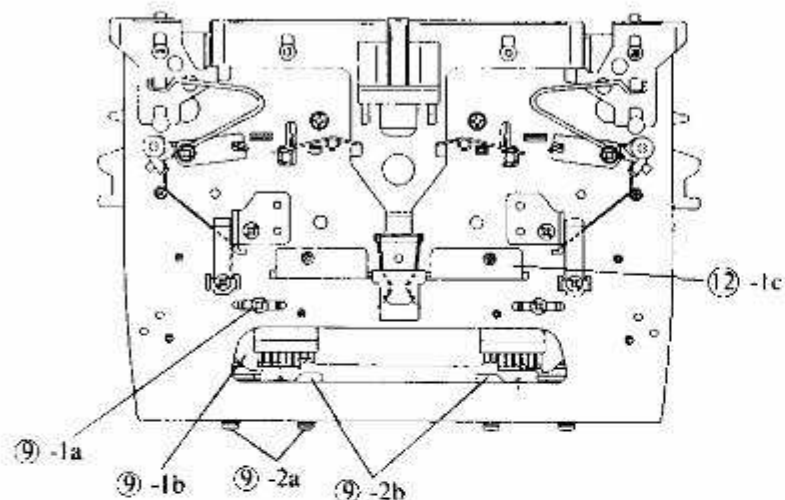

Name of parts

9-1a	Screw 3.18	40 × 4
9-1b	Spring plate	
9-2a	Screw 3.18	40 × 5
9-2b	Needle transfer plate	
10-1a	Screw 3.18	40 × 5
10-1b	Yarn presser brush	
10-2a	Flat screw	
10-2b	Magnet	
11-1a	Rubber wheel screw	
11-1b	Rubber wheel	
11-2a	Screw 3.18	40 × 4
11-2b	Cam plate	
12-1a	Screw 3.18	40 × 8
12-1b	L front foot	
12-1c	L front foot holder	
13-1a	Screw 3.18	40 × 7
13-1b	Rear foot	
13-1c	End needle selection spring	
13-2a	Screw 3.18	40 × 8
13-2b	Main cam	
13-2c	Lace selecting cam	
13-2d	End needle selection cam	
13-2e	End needle selection change cam	
13-2f	End needle selection plate	

9. Removing the spring plate and the needle transfer plate

***Note;** Do not remove the spring plate and the needle transfer plate except replacing them.

- 9.1 Remove the spring plate screws and remove the left and right spring plates.
- 9.2 Remove the needle transfer plate screws and remove the left and right needle transfer plates.

10. Removing the yarn presser brush and magnet

- 10.1 Remove the yarn presser brush screws from the rear of L carriage and remove the left and right yarn presser brushes.
- 10.2 Remove the magnet screws from the rear of the L carriage and remove the left and right magnets.

11. Removing the cam plate

***Note;** Do not remove the cam plate except replacing it.

- 11.1 Remove the rubber wheel screws and remove the left and right rubber wheels (there is spring washer under the screws).
- 11.2 Remove the cam plate screws and remove the cam plate.

12. Removing the front foot

- 12.1 Remove the four front foot screws from the rear of the L carriage and remove the L carriage front foot and the L front holder.

13. Removing the Main cam and rear foot

***Note;** Do not remove the Main cam except replacing it.

- 13.1 Remove the four screws from the rear foot and remove the rear foot and the left and right end needle selection spring for L will come off.
- 13.2 Remove the two screws from the front two sides of main cam, with the reinforcing plate B and two valve cam B to the Main cam, remove the Main cam. At the same time, the lace selecting cam, the end needle selection cams, the end needle selection change cams, and the end needle selection plates will come off.

10.2 Assembling the L carriage

1. Mount the Main cam

- 1.1 Mount the end needle selection cam (right and left), the end needle selection change cam (right and left), the end needle selection plate (right and left) and the lace selection cam to the Main cam.
(Refer to Fig. 10-1).

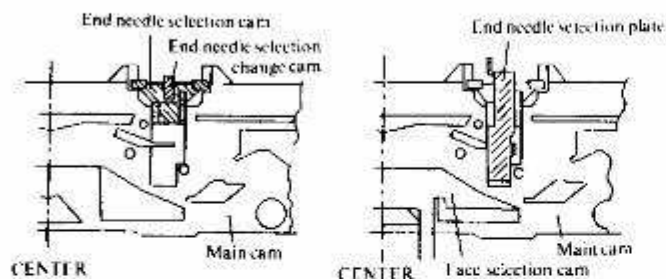

Fig. 10-1

- 1.2 Mount the Main cam to the L carriage plate, on which the above parts are mounted (refer to Fig. 10-2).

After that, tighten the Main cam lightly with two screws 3.18 — 40 × 8 (right and left), while pushing Main cam toward "arrow" direction (refer to Fig. 10-3).

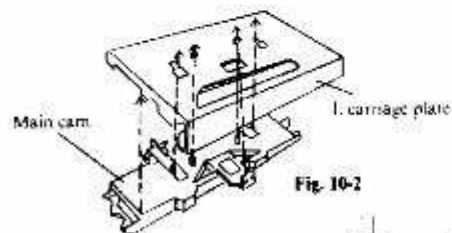

Fig. 10-2

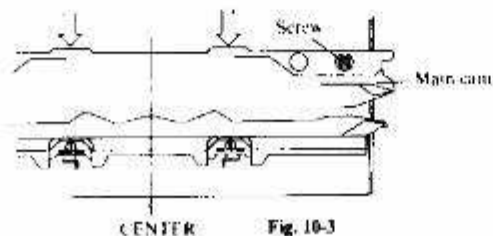

Fig. 10-3

2. Mount the Rear foot

- 2.1 Mount the end needle selection cam springs (right and left).
(Refer to Fig. 10-4)
- 2.2 Mount the rear foot to the Main cam and tighten the four screws (3.18 — 40 × 7), while pushing it toward the "arrow" direction (Refer to Fig. 10-5).

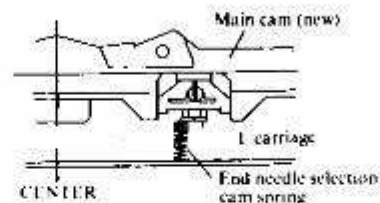

Fig. 10-4

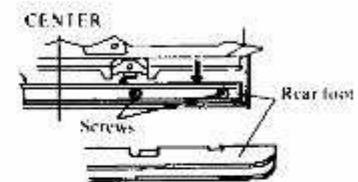
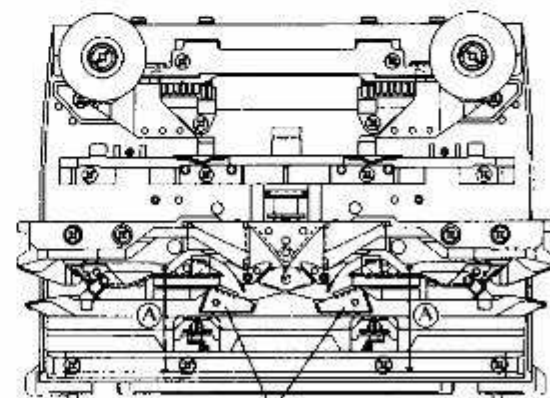

Fig. 10-5

3. Adjust the mounting dimension the Main cam and mount the end needle separation cam

- 3.1 After Mounted the Rear foot and the Main cam, adjust the dimension (A) in Fig. 10-6 (between Both inner faces of cam) within $45.2 \text{ m} / \text{m} \pm 0.1 \text{ m} / \text{m}$, and tighten the two screws of the Main cam.
- 3.2 Mount the end needle separation cam (right and left) and tighten them from front side with screws (3.18 × 12 with washer), while pushing them toward "arrow" direction (Refer to Fig. 10-6).



End needle separation cam

* Dimension (A) : $45.2 \pm 0.1 \text{ m} / \text{m}$

Fig. 10-6

*** Other way to adjust the mounting dimension of the Main cam**

If you made the adjustment tool as shown in Fig. 10-7, you can adjust dimension (A) easily.

At first, place the adjustment tool between the Rear foot and the Main cam, then tighten the Main cam with two screws, while pushing it toward the "arrow" direction (Refer to Fig. 10-7).

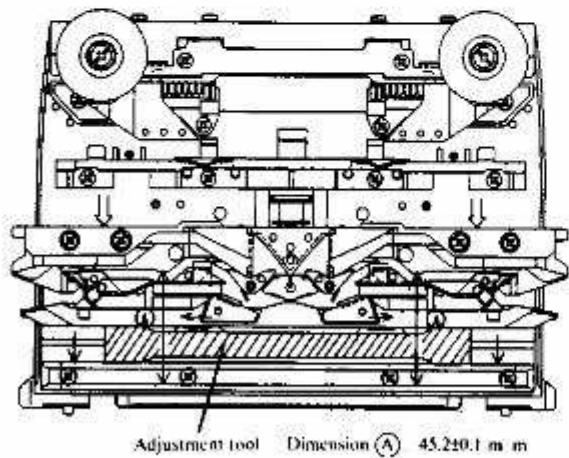
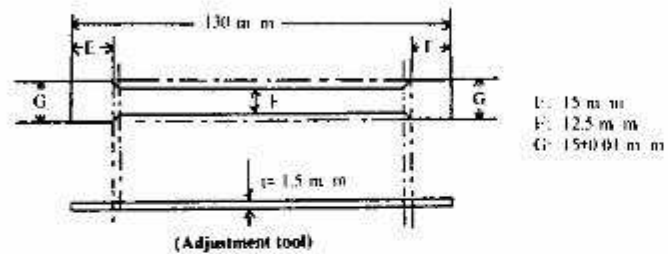
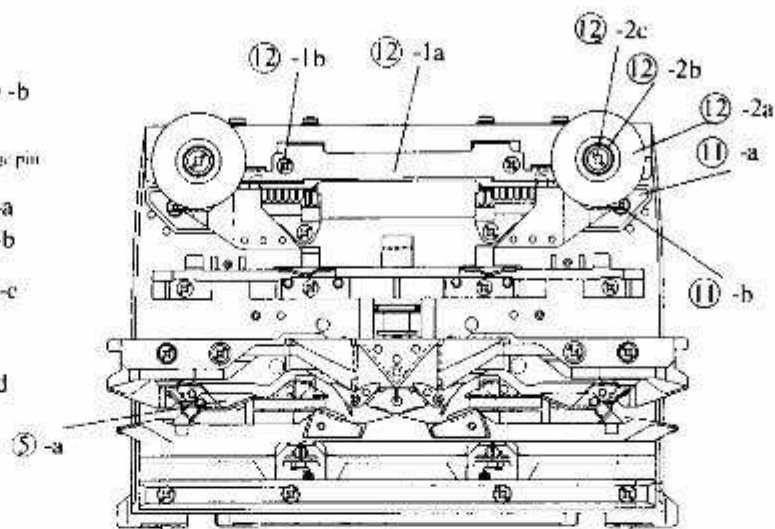
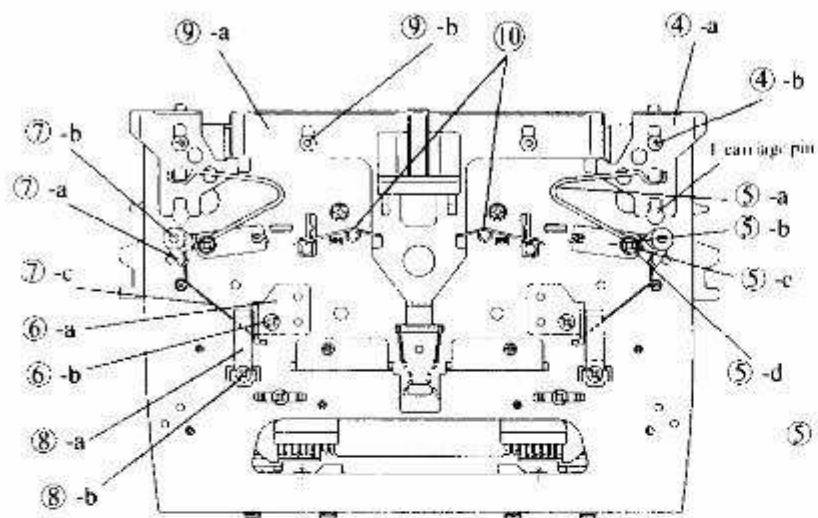

Fig. 10-7



Name of parts

- ④-a Connecting plate
- ④-b Stud nut
- ⑤-a Separation cam
- ⑤-b Separation cam plate
- ⑤-c Connecting plate spring
- ⑤-d Washer 3.3
- ⑤-e Screw 3.18 - 40 × 7
- ⑥-a L handle setting base
- ⑥-b Screw 3.57 40 × 5
- ⑦-a Valve cam C
- ⑦-b Lever shaft (stud screw)
- ⑦-c Valve cam C spring
- ⑧-a L handle spring
- ⑧-b Screw 3.57 40 × 4
- ⑨-a Release button plate
- ⑨-b Stud nut
- ⑩ Change lever spring
- ⑪-a Magnet
- ⑪-b Screw (flat head screw)
- ⑫-1a Cam plate
- ⑫-1b Screw 3.18 40 × 4
- ⑫-2a Rubber wheel
- ⑫-2b Spring washer
- ⑫-2c Stud screw

4. Mounting the Connecting plate

Push the right side connecting plate onto the L carriage plate pin and tighten it with the stud nut.

* Mount both the right and left sides in the same manner.

5. Mounting the Separation cam

Mount the right side separation cam to the carriage plate from rear side of the carriage plate, and mount the separation cam plate, connecting plate spring and washer, then tighten them with screw (3.18 - 40 × 7).

After that, hook the connecting plate spring on the connecting plate.

* Mount both the right and left sides in the same manner.

6. Mounting the Handle setting base

Mount the right and left handle setting bases, respectively, with their screws (3.57 40 × 5).

7. Mounting the Valve cam C

Mount the valve cam C with the lever shaft (stud screw), and mount the valve cam C spring. The short stem of the valve cam C spring goes in the valve cam

C hole, and long side hooks onto the handle setting base.

* Mount both the right and left sides in the same manner.

8. Mounting the L handle spring

Mount the L handle spring left and right with screws (3.57 - 40 × 4).

9. Mounting the Release button plate

Mount the release button plate to carriage, and tighten it with stud nut at two points.

10. Mounting the Change lever spring

Mount the change lever spring onto carriage plate.

11. Mounting the Magnet

Mount the left and right parts of the magnet with screws (flat head screw).

12. Mounting the Rubber wheel and the cam plate

12.1 Push the cam plate lightly toward the front foot and tighten it with screws (3.18 40 × 4).

12.2 Mount the right and left parts of the rubber wheel and spring washer with screws (stud screws).

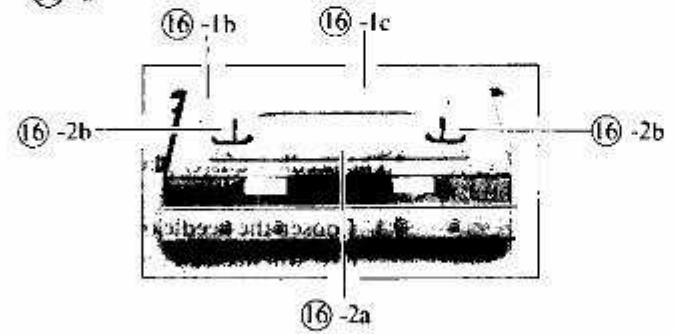
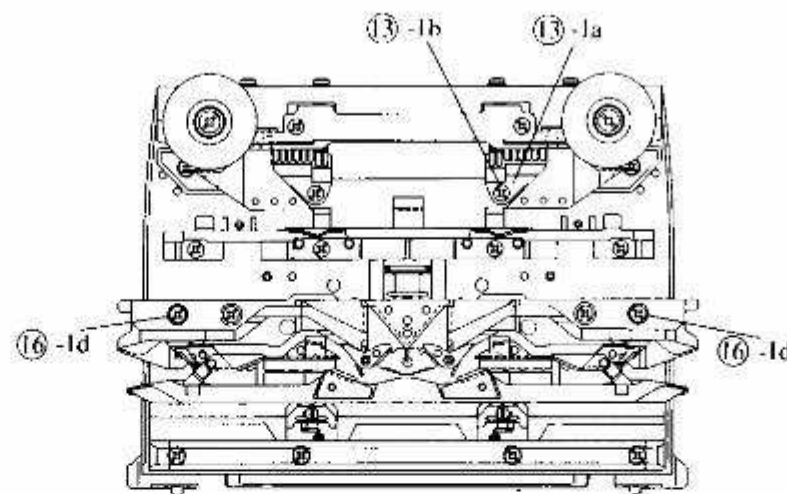
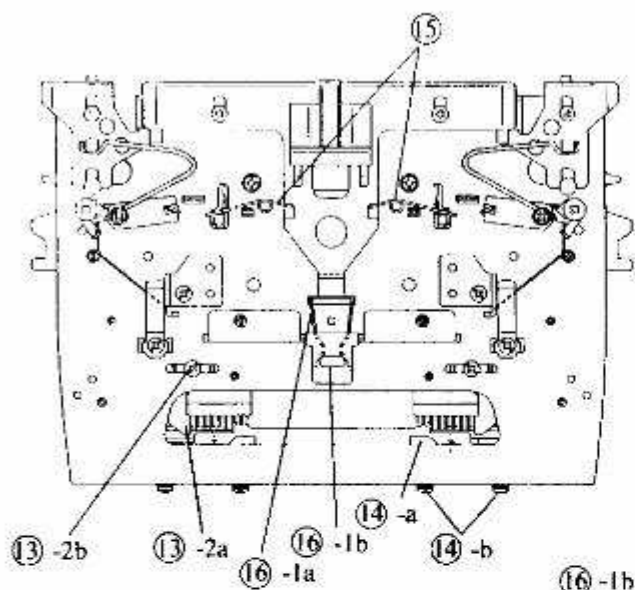

Name of parts

- 13-1a Yarn presser brush
- 13-1b Screw 3.18 40 × 4
- 13-2a Spring plate
- 13-2b 3.18 - 40 × 4
- 14-a Needle transfer plate
- 14-b Screw with washer
- 15 End needle selection change spring
- 16-1a Change lever spring
- 16-1b Lace selecting knob
- 16-1c L carriage cover
- 16-1d Screw 3.18 — 40 × 4
- 16-2a L carriage handle
- 16-2b Screw

- 13. Mounting the Yarn presser brush and the spring plate**
 13.1 Mount the yarn presser brush right and left screws (3.18 — 40 × 4).
 13.2 After lightly tightening the screws on the spring plate right and left, and adjusting the horizontal position of them (refer to page 47), and tighten the screws.
- 14. Mounting the Needle transfer plate**
 Lightly tighten the screws (screw with washer) on the needle transfer plate, adjust the right and left sides (refer to page 48), and tighten them.

- 15. Mounting the End needle selection change spring**
 Place the right and left end needle selection change spring.
- 16. Mounting the L carriage cover and the L carriage handle**
 16.1 Place the change lever spring and the lace selecting knob and mount the L carriage cover, then tighten it with two screws (3.18 - 40 × 4).
 16.2 Place the L carriage handle on the handle setting base and mount the handle screws.

10.3 How to Adjust the I. Carriage

1. Adjusting the horizontal position of the spring plate

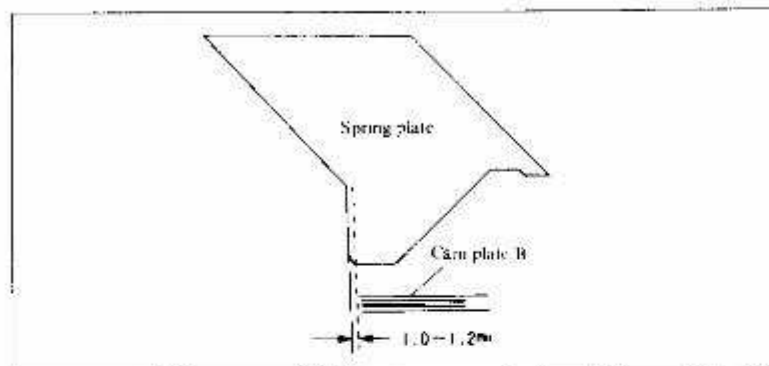

Figure 10-8

- 1.1 Remove the I. carriage cover and loosen the left and right plate spring screws.
- 1.2 Secure the spring plate to a position within 1.0 - 1.2 mm from the face of cam plate B and tighten it with screws.

2. Adjusting the vertical position of the spring plate

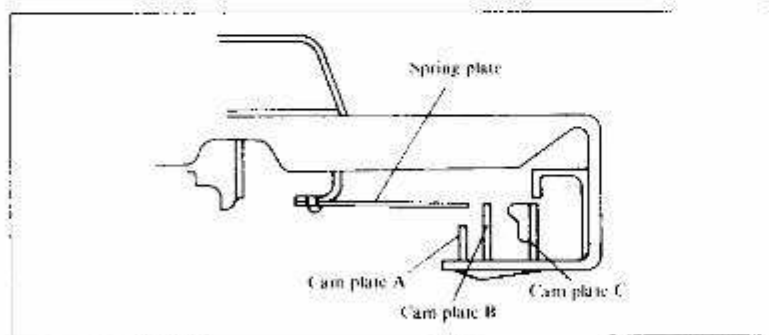

Figure 10-9

- 2.1 Prepare cam plate B by placing the tip of the spring plate at the same height as cam plate B.
- 2.2 Be sure not to bend any part of the spring when making the adjustment with pincers or pliers.

3. Adjusting the position of the needle transfer plate

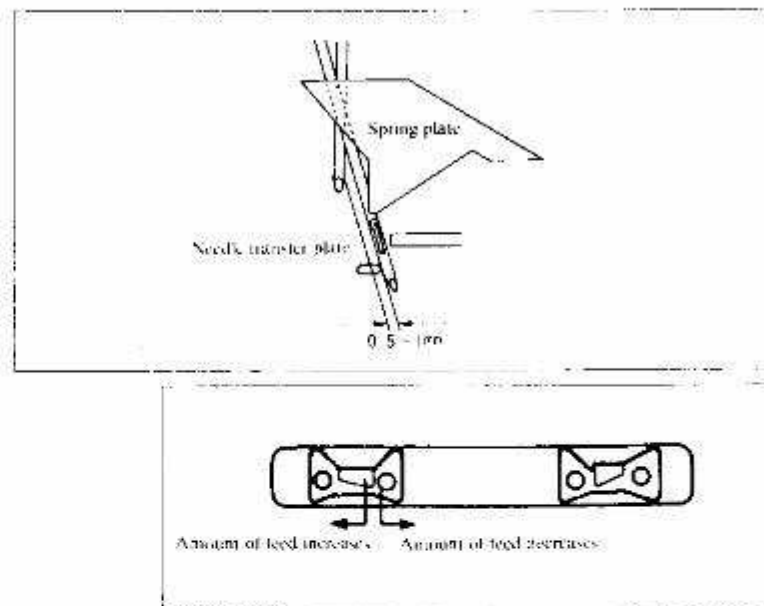

Figure 10-10

- * The needle transfer plate is secured by the needle transfer plate screws on the sinker plate side.
- 3.1 Loosen the needle transfer plate screws. When the tab is moved inward the feed will decrease, and when it is moved outward the feed will increase.
 - 3.2 Adjust so that the gap between the two intersecting needles is 0.5 - 1.0 mm at the point at which they separate from the feed tab.

4. How to adjust the sinker plate bend

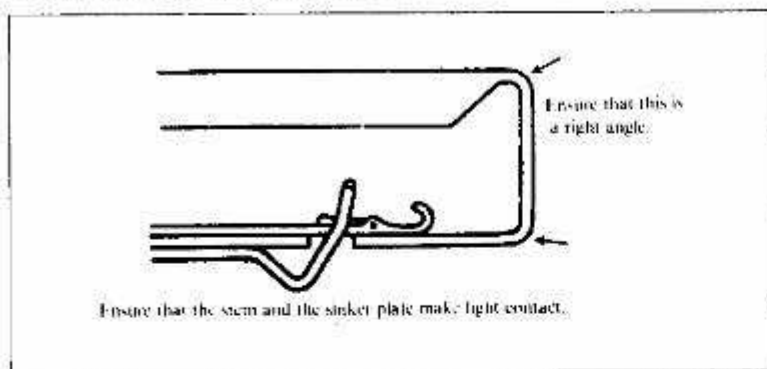

Figure 18-13

- 4.1 Put the L carriage over the needle bed, extend the knitting needles to position D, and check the gap between the L carriage sinker plate and the knitting needle stems. If the needles have been brought higher than the sinker plate, or if there is a gap, assume that the sinker plate is bent. Correct the bend in such a way that there is light contact made between the stems and the sinker plate.

11. DISASSEMBLY AND ASSEMBLY OF THE MAIN BODY

11.1 Disassembling

1. Removing the panel

* Removal sequence: first, the pattern case whole unit is removed, and then the accessory box assembly.

1.1 Removing the pattern case whole unit

Remove the two screws, and then, while lifting the left side of the panel, slide it to the left and remove it from the right of the lower side plate, turning it over and then upside down toward the rear of the main body.

* There are five connectors jointed to the main PC board on the rear of the pattern case whole unit which make it difficult to raise the operation panel. Be sure to exercise sufficient caution when raising the pattern case whole unit so as not to damage these connectors.

1.2 Disconnect the five connectors from the main PC board at the rear of the pattern case whole unit.

1.3 Remove the one screw from the cord cover and remove the earth of the main PC board.

2. Removing the accessory box assembly

2.1 Remove the screw (inside the accessory box), then, while raising the right side of the assembly, slide it toward the right and removed it from the left of the lower side plate.

3. Removing the main body

3.1 Remove the screw from the carrying case reinforcing plate.

3.2 Remove the two screws from the yarn tension stand.

3.3 Remove the two screws each from both the left and right of the needle bed.

3.4 Remove one screw from both the left and right of the front needle bed.

3.5 Remove two main body screws each from both the left and right of the rear of the main body, and then remove the table clamp setting plate.

3.6 Raise the right side of the needle bed gently and slide it toward the right, removing the from the bottom of the case.

4. Removing the left position sensor PC board and the right position sensor PC board

4.1 Take the screws from each of the PC boards and remove them.

5. Removing the cord cover

5.1 Remove the screw from the cord cover and remove the cord cover.

6. Removing the belt

6.1 Loosen the pulley adjusting plate screws (Ref. No. C-47) on the pulley holder plate on the left side of the main body.

6.2 Turn the pulley to move the belt joint before you to the center of the main body.

6.3 Remove the belt screws from the hole and remove the belt.

7. Removing the needle selector unit (with needle selector plate holder)

<Check the distance between the needle selector plate holder and the front needle bed>

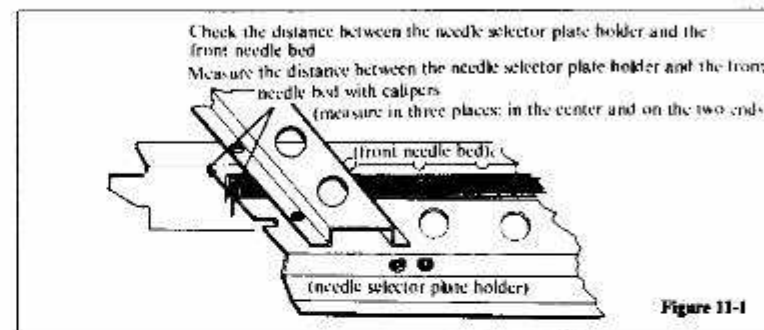

Take the measurements given the figure above and write them down, following the same measurements again during reassembly.

Note:

1. Do not remove the 7 screws on the needle selector plate holder and the 5 screws on the needle selector unit unless the needle selector unit is being disassembled.
2. When adjusting the mounting measurements of the gate peg, the stay need not be removed.
3. In the repair of the main body rotary cam lever and N.S.P. operation levers, the source of the problem may be discovered by removing the needle selector solenoid, the rotary cam lever holder, and the cam lever spring presser plate.
- 7.1 When the lower holder plate, yarn tension stand and the 14 screws with washers on the two gate peg right and center stays are removed, the needle selector unit and needle selector plate holder will come off as a single assembled unit.

8. Removing the needle selector plate holder from the needle selector unit

8.1 When three needle selector plate holder screws are removed, one from the center stay and two from the right stay, the needle selector unit comes off the needle selector plate holder. The 16 N.S.P. operation levers in the needle selector plate holder and the needle selector unit also come out.

9. Removing the needle selector plate holder

9.1 Remove the center stay, the two operation lever presser screws, and the operation lever presser.

9.2 Remove the eight needle selector plate springs. (Make sure of the mounting direction and position of the springs before removing them.)

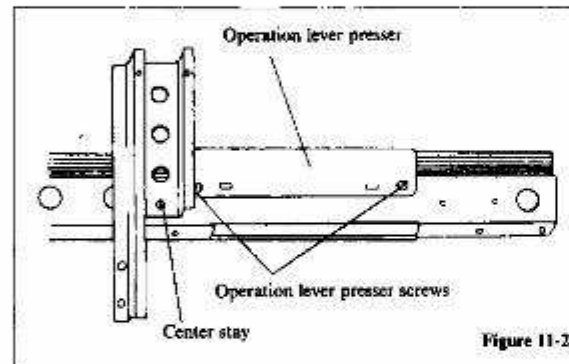

Figure 11-2

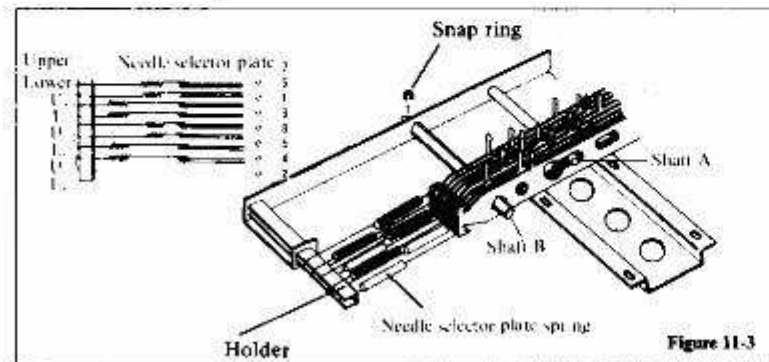

Figure 11-3

9.3 Remove the needle selector plate shaft B (angled) snap ring 2.5 from the rear side of the needle selector plate holder and pull the needle selector plate shaft out toward you.

9.4 Sliding each of the 8 needle selector plates toward the right, one by one, take them off the 6 grooves on shaft A

10. Disassembly of the needle selector unit

10.1 Remove the screw from the encoder board holder plate.

10.2 Remove the 4 screws from the encoder PC board and remove the encoder PC board

10.3 Removing the needle selection solenoid unit.

When the two screws are removed, the needle selection solenoid unit will come off.

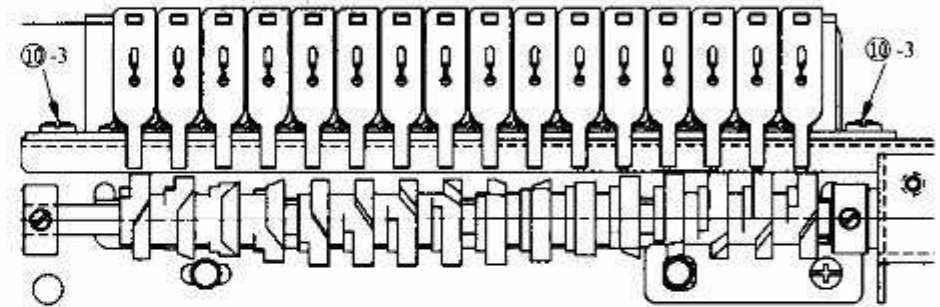

Figure 11-4

10.4 Removing the rotary encoder

(1) Remove the encoder board holder after removing the two screws and washers.

(2) Take the snap ring and washer from the rotary encoder shaft and remove the rotary encoder.

Note:

The washer on the rear of the rotary encoder has grease on it so be cautious that it is not lost when it comes off.

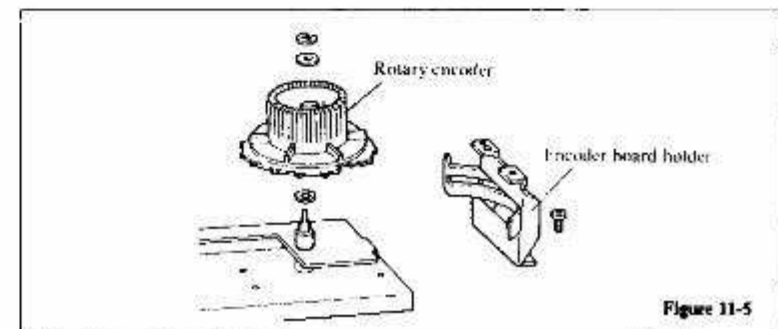
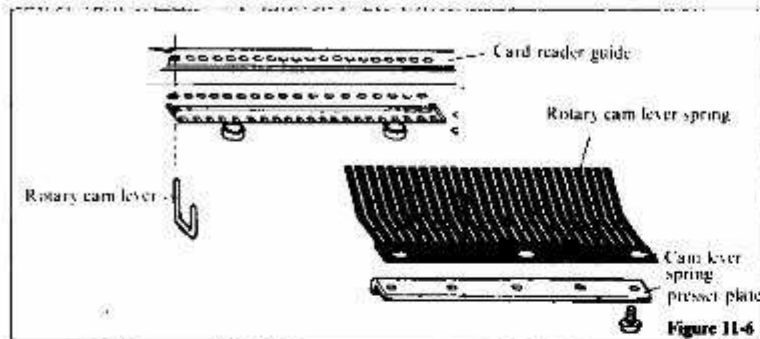

Figure 11-5

10.5 Removing the rotary cam lever

- (1) When the five cam lever spring presser plate screws are taken off, the cam lever spring presser plate and rotary cam lever spring come off and the 16 rotary cam lever may be taken out.



10.6 Removing the rotary cam

- (1) Take out the bevel gear spring pin and the slit disc spring pin.
- (2) Loosen the right and left rotary cam adjuster collar screws.
- (3) Take out the rotary cam holder (left) screws and then the rotary cam holder.
- (4) When the rotary cam is pulled toward the left and out of the rotary cam holder (right), the bevel gear and spacer will come out.
- (5) Take out the slit disc.

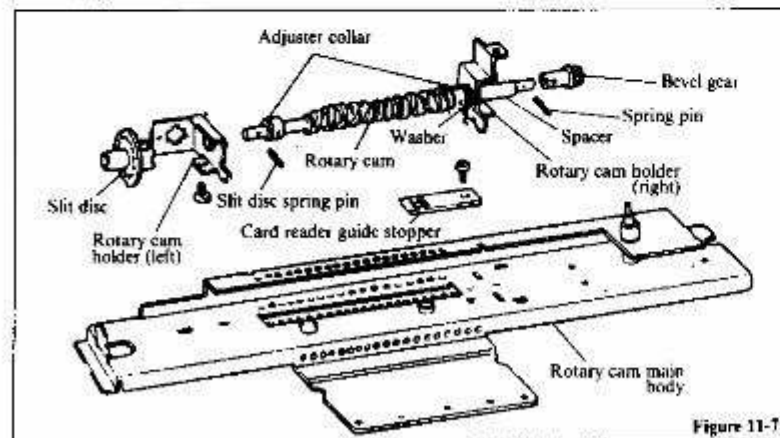

11.2 Assembling the Main Body

1. Mounting the needle selector unit

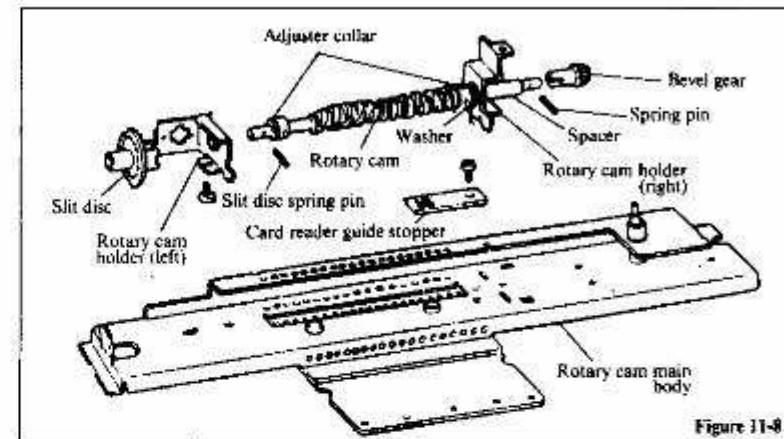

1.1 Mounting the rotary cam

- (1) Place the adjuster collars onto both ends of the rotary cam.
- (2) Place the washers onto the side of the rotary cam with the bevel gear spring pin hole, pass it over the rotary cam holder (right), place the spacer on, knock the bevel gear spring pin into its hole, and put the bevel gear on.

- (3) Insert the rotary cam holder (left) onto the other side of the rotary cam and insert the slit disc and install it to the main body.
- (4) Knock the slit disc spring pin into place.

Note:

Do not put the slit disc spring pin in so that it is even on both sides (As shown in Figure 11-10)

- (5) Lightly oil the resin part of the rotary cam, the metal part of the bearing of the rotary cam holder right and left, and the teeth of the bevel gear with a soap based grease (Epinoch #1).

1.2 Mounting the rotary cam lever

- (1) Apply grease (Epinoch #1) to the card reader guide stopper hole on the rotary cam main body.
- (2) Insert the long side of the rotary cam lever into the guide hole of the main body, and insert the short side into the guide hole on the rotary cam lever.

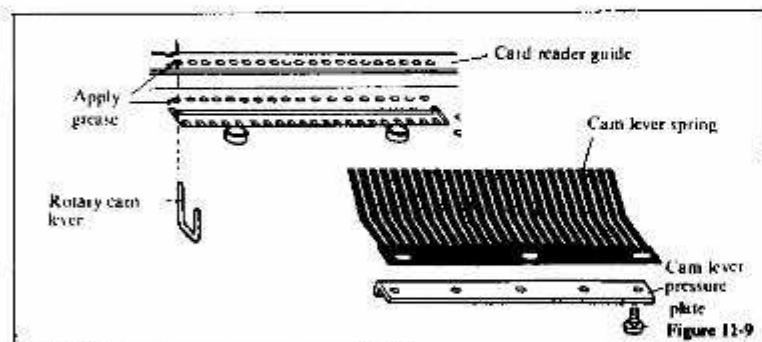

- (3) Apply grease to parts which come in contact with the rotary cam lever and cam lever spring and install the cam lever spring and the cam lever spring pressure plate. Install the cam lever spring pressure plate such that the side with the bend is toward the rotary cam lever.

1.3 Mounting the rotary encoder

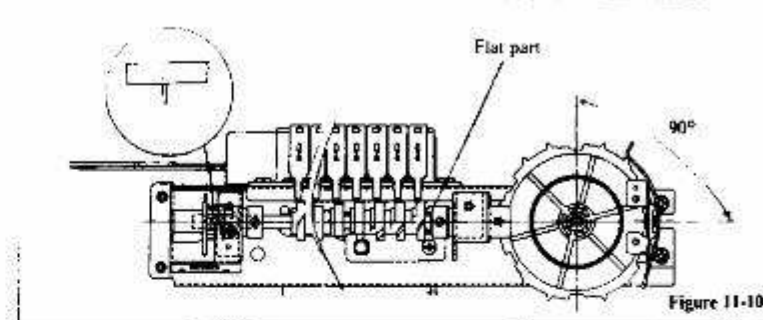

- (1) Turn the rotary cam until the flat part of rotary cam's right end is horizontal, as shown in the figure (11-10).
- (2) Put the washer on the rotary encoder and place the rotary encoder such that its relationship to the rotary cam is as shown in Figure 11-10.
- (3) Put the washer on and secure it with a snap ring.
- (4) Mount the encoder board holder.

Note:

Apply grease (Epinoch #1) to the teeth of both the bevel gear and the rotary encoder.

1.4 Mounting the needle selector unit

- (1) Place the needle selection solenoid armature on the tip of the rotary cam lever and install the two installation screws.

2. Mounting the needle selector plate holder

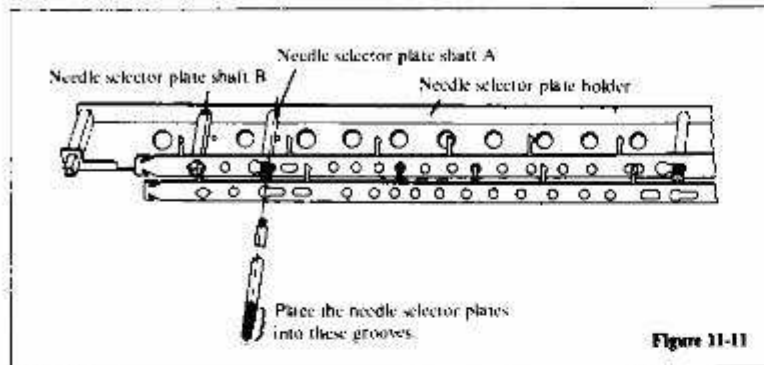

2.1 The needle selector plate holder should be mounted in the following sequence:

(1) Fit needle selector plate number 7 into the six grooves in needle selector plate shaft A of the needle selector plate holder, and, sliding it toward the left, push it in (refer to figures 11-11).

*The grooves in needle selector plate shaft A go, from the needle selector plate holder side, in the following sequence: 7, 5, 1, 3, 8, 6, 4, and 2. Exercise sufficient caution in this regard when pushing the needle selector plates into the needle selector plate holder.

*Also be cautious to ensure that the plates are not bent so far that they break when being inserted.

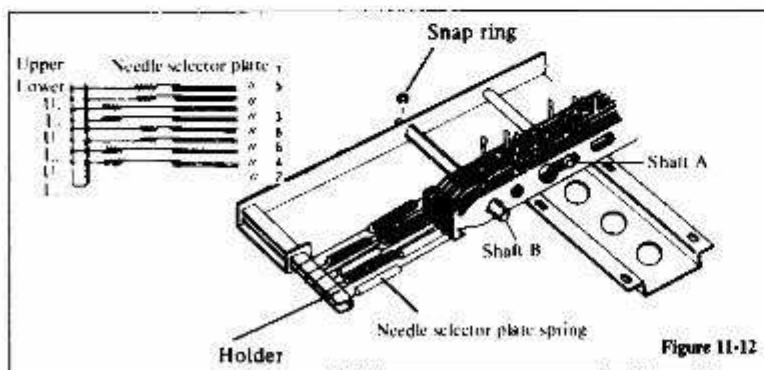

(2) Next hook the needle selector plate spring onto needle selector plate 7 and the needle selector plate holder spring hook.

*The needle selector plate spring should be hooked as follows: 5, 3, 6, and 2, from the needle selector plate holder side, should be hooked to the spring hook on the lower side of the needle selector plate. The remaining plates, 7, 1, 8, and 4 should be hooked on the spring hook on the upper side of the needle selector plate.

*The springs should be hooked alternately to the top and bottom of the plates.

(3) Next place needle selector plate 5 to the needle selector plate holder in the sequence given in 1) and 2) above. Similarly, place the remaining needle selector plates, 1, 3, 8, 6, 4, and 2 to the needle selector plate holder, in that sequence (refer to figure 11-12).

(4) After placing the needle selector plates, insert needle selector plate shaft B (angled) and secure it with a snap ring 2.5 (refer to figure 11-12).

3. Mounting the needle selector unit and the needle selector plate holder to the main body

3.1 Mount the needle selector plate holder and the needle selector unit to the center and right stays. The mounting holes in the center and right needle selector plate holder stays and in the needle selector unit are oblong horizontal holes, so use the center of the hole and tighten only lightly.

3.2 Put the 16 N.S.P. operation levers through the holes in the needle selector plate and into the left side of the rotary cam lever and mount the N.S.P. operation lever presser.

4. Mounting the needle selector unit and the needle selector plate holder to the main body

4.1 Place the needle selector plate shaft B of the needle selector plate holder into the angled hole in the main body.

4.2 Put one screw into each of the oblong, vertical holders in the main body for the installation of the center and right stays, tightening it only lightly.

4.3 Adjust the center of the rotary encoder so that it has the same relationship as in the above figure and tighten the center and right stays.

4.4 Install the table clamp setting plate and yarn take-up stand in such a way that the main body and the needle selector plate holder will be set in parallel with each other.

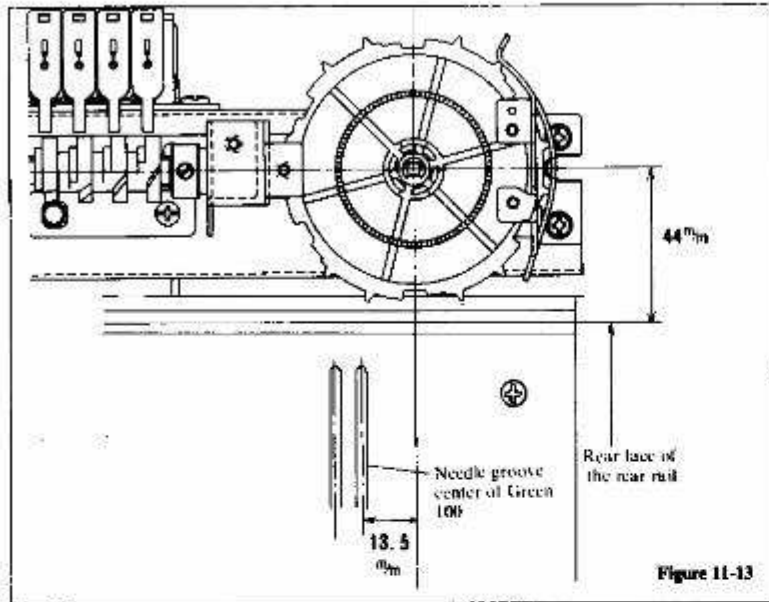

Figure 11-13

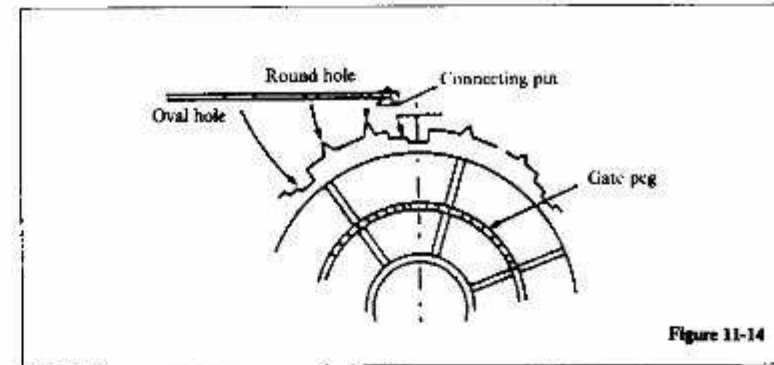

Figure 11-14

5. Mounting the belt

- 5.1 Take the belt connecting pin such that it is on the inside and place it on the belt cover (right) groove, fitting onto the rotary encoder as shown in the figure 11-14.
- 5.2 Turn the rotary encoder pulley by the rib and pull out the rear rail side. When turning the rotary encoder, be certain not to turn it by the comb.
- 5.3 On the left side, similarly, place the belt so that the long hole in it is matched to the notch in the pulley and pull out to the rear rail side.
- 5.4 Pull both ends of the belt together so that the connector pins link with the joint hole in the other.
- 5.5 Adjust the pulley adjusting plate. (Ref. No. C-46) With the pulley pushed toward the right, adjust it so that it can move 0.3 to 0.6 mm and tighten the screws.

6. Mounting the encoder PC board

- 6.1 Fit the encoder PC board to the encoder board holder plate, rotary cam holder L and tighten it up with the four screws.
- 6.2 Place the encoder board holder plate and secure it with one screw.
- 6.3 Place the board cord cover and secure it with two screws. (Tighten the right screw only lightly.)

7. Mounting the left position sensor PC board and the right position sensor PC board.

- 7.1 Tighten each of the PC boards down with screws.

8. The main body housing

- 8.1 Place the needle selector plate holder on the left side of the main body over the left lower side plate and put the main body under the case.
- 8.2 Fit and tighten the one screw on each the left and right front portions of needle bed.
- 8.3 Fit and tighten the two screws on each the left and right needle beds.
- 8.4 Fit and tighten the two installation screws on the yarn tension stand.
- 8.5 Fit and tighten the screw on the carrying case reinforcing plate.
- 8.6 Mount the left and right parts of the table clamp setting plate from the rear of the main body and tighten each down with two screws.

9. Mounting the accessory box assembly

- 9.1 Insert the left part of accessory box into the left lower side plate.
- 9.2 Tighten the screw inside the accessory box. (the cord for the left position sensor PC board should pass through the rear of the case).

10. Mounting the pattern case whole unit

- 10.1 Insert each of the connectors to the main PC board, rear of the pattern case whole unit (in five places).
- 10.2 Remove the right side screw of the board cord cover and earth terminal.
- 10.3 Insert the right part of pattern case whole unit into the lower side plate right.
- 10.4 Mount the pattern case whole unit as the encoder code and two solenoid codes do not touch the slit disc and needles.
- 10.5 Fit and tighten the two installation screws.

14.3 How to adjust the needle bed comb (Ref. No. B-2 In Parts catalogue)

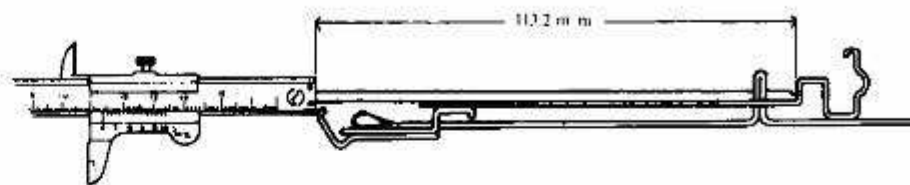

Figure 11-16

1. Take out the machine body from the lower case assembly (see P. 36).
2. Loosen 9 clamping screw for needle bed comb on stay right, center, and lower holder plate.
3. Loosen 12 clamping nuts on the back side of combs with a wrench.
4. Put out three needles each at both ends and in the central part of the needle bed and determine a position of combs so as to let needles come to midway between both combs. (Bilateral adjustment)
5. Set fitting measurement of combs at 113.2 mm at both ends and in the central part of the machine body and fasten with clamping nuts. (longitudinal adjustment)

* Note

In this case, keep it in mind that if such nuts are tightened too hard, screw will be twisted off.

Adjust measurement of fitting combs by use of a sliding calipers and fasten with clamping nuts (refer to Fig. 11-16).

12. ADJUSTMENT AND CHECK OF THE NEEDLE SELECTOR MECHANISM

12.1 Adjusting the Card Reader Guide Plate

- (1) Remove the pattern case whole unit and then remove the cord cover. The pattern case whole unit should be placed, with connectors still joined, to the rear of the main body.
- (2) Connect the AC adapter.
- (3) Turn the switch on and the INPUT key on.
- (4) Align all of the knitting needles to position A, set the K carriage change knob to <KC>. When the K carriage is operated, needle selector solenoids are all energized to be attracted.
- (5) Loosen the screws on the card reader guide stopper. Then, after sliding the card reader guide stopper over to the right, slide it very lightly back to the left, and tighten the screws such that the right window of the card reader guide plate lightly touches the contact.

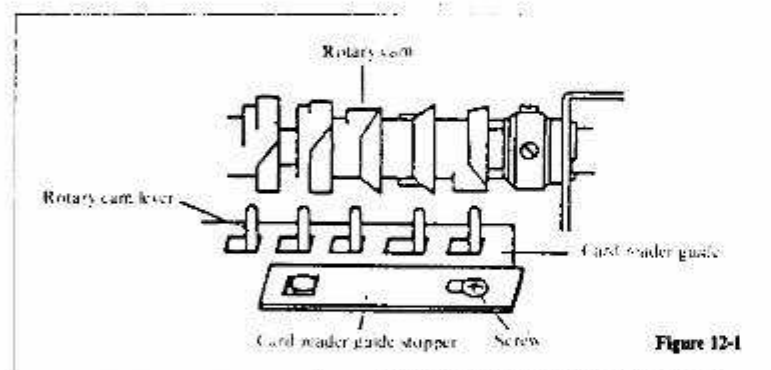

12.2 Adjusting the Rotary Cam Position

- (1) Turn the switch on and the INPUT key on.
- (2) Align all of the knitting needles to position A, set the K carriage knob to <KC>. When the K carriage is operated, needle selector solenoids are all energized to be attracted.
- (3) After the completion of the card reader guide plate adjustment, loosen the four stop screws on the rotary cam adjuster collar and the rotary cam presser collar.
- (4) With a feeler gauge make a 0.9 ~ 1.2 mm (TYP 1.0 mm) gap between the rotary cam and the rotary cam lever. Then, holding the rotary cam to the right with a flat head screw driver, tighten the screw (if no feeler gauge is available, approximate the distance visually).

- (5) Make a 0.2 mm gap between the rotary cam presser collar and the left rotary cam holder and tighten the screws. Tighten the four screws each twice to make sure that they are tight.
- (6) Place all the knitting needles at position B.
- (7) Turn the power switch off, turn the K carriage change knob to <KC> and check all needles are selected to position D when the carriage is moved slowly and when it is moved quickly.
 - * The movement of the K carriage is unusually sluggish when there is no gap in the rotary cam pressure collar or when the gap in the rotary cam adjuster collar is too great.
 - * When there are needles which do not come out to position D, make the gap in the rotary cam adjuster collar greater.

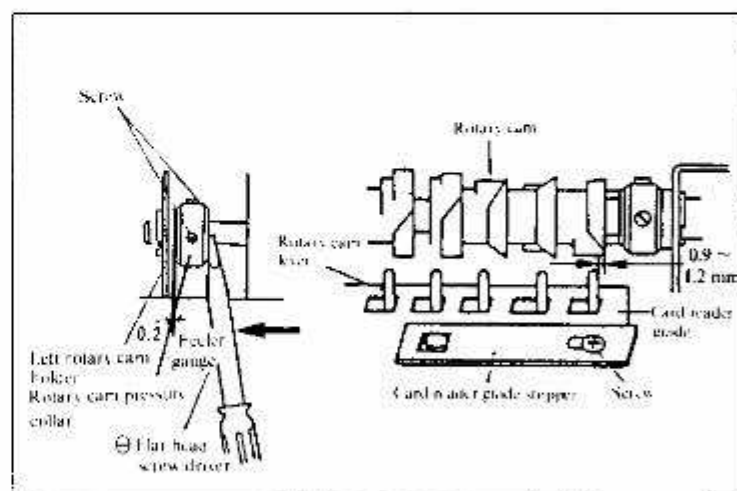

12.3 Checking the Needle Selector Mechanism

1. The objectives of check sequence 1

First of all, in order to determine whether the cause of the error in needle selection is in the needle selection mechanism (the mechanical portion), or in the electronic portion, move the carriage with the power turned off.

When the power is turned off, the solenoids are also all off, all of the rotary cam levers are on the rotary cams, and the knitting needles should all be selected to position D.

With this test, the carriage needle selection mechanism, the rubbing surfaces of the needle selection solenoid armature, the rotary cam, the rotary cam levers, the N.S.P. operation levers, and the needle selector plate may be checked.

2. When the test determines that not all of the needles come out to position D, but that some remain in position B.

(1) When there is no regularity (e.g., 8 pitches, 16 pitches, etc.) in the needles remaining in position B

- The knitting needles are bent.
- The belt has not been properly mounted to the rotary encoder.
- The rotary cam has not been properly mounted to the rotary encoder.
- The card reader guide plate or the rotary cam position are out of adjustment.

(2) When the needles remaining the position B show regularity (8 pitches or $8 \times n$ pitches)

- The needle selector plate is not moving because the rotary cam levers and N.S.P. operation levers have not been mounted properly.
- The rotary cam lever is getting caught on the card reader guide and, slipping, do not move. * Apply grease.
- The needle selector solenoid armature and the solenoid yoke are getting caught, and, slipping, do not move.

d. The armature spring of the needle selector solenoid is bent or has come loose.

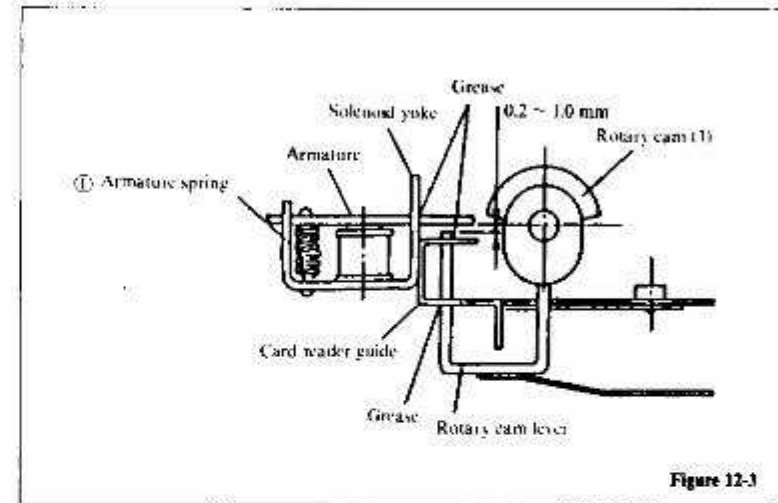

e. The N.S.P. operation lever stay is interfering with needle selector plate number 2.

f. The needle selector plate springs are loose or are interfering with one another.

3. When carriage operation is much heavy

a. The carriage will not move

The carriage will not move when the rotary cam lever has come loose from the face of the rotary cam. When too much pressure is applied to the rotary cam lever, it will bend. After checking to ensure that the rotary cam lever has not become bent, adjust the positions of the card reader guide plate and the rotary cam.

b. Carriage operation is not smooth

The rotary cam presser collar is making contact with the metal portion of the left rotary cam holder bearing. The gap between the rotary cam and the rotary cam adjuster collar is too wide.